

# STANDARD

## COMPONENTS / KOMPONENTEN

Specifications and Dimensions for Standardized Tubes, Fittings and Connections.

Spezifikationen und Abmessungen für genormte Rohre, Formteile und Verbindungen.



## Qualities and Specifications

Qualitäten und Spezifikationen

Page / Seite 4- 21



## Dockweiler Cap and Endcaps

Dockweiler Cap und Endkappen

Page / Seite 59-62

## Clamps, Gaskets and Connections

Klammern, Dichtungen und Verbindungen

Page / Seite 63-88



## COAX Tubes and Fittings

COAX Rohre und Formteile

Page / Seite 89-98

## Tubes

Rohre

Page / Seite 23-27

## Elbows

Bögen

Page / Seite 29-36

## Technical Hoses

Technische Schläuche

Page / Seite 99-101



## T-Pieces

T-Stücke

Page / Seite 37-47

## Reducers

Reduzierungen

Page / Seite 49-57

## General Information

Allgemeine Informationen

Page / Seite 103-119



**Disclaimer for contents:** The contents of the catalog have been prepared with the greatest care. However, Dockweiler AG does not assume any liability for the correctness, completeness, reliability, usability and validity of the contents. The same applies to other Dockweiler companies that use this term. The respective customer is therefore obliged to check all contents in advance for their suitability for the intended use or to have them checked by a qualified professional.

**Haftung für Inhalte:** Die Inhalte des Katalogs sind mit größter Sorgfalt erstellt worden. Für die Richtigkeit, Vollständigkeit, Verlässlichkeit, Brauchbarkeit und Aktualität der Inhalte übernimmt die Dockweiler AG jedoch keine Gewähr. Das Gleiche gilt für andere Dockweiler Unternehmen, die diese Klausel verwenden. Der jeweilige Nutzer ist daher grundsätzlich verpflichtet, sämtliche Inhalte vorab auf ihre Tauglichkeit für die von ihm geplante Verwendung fachmännisch zu prüfen oder prüfen zu lassen.

## Finest inner surfaces for reliable manufacturing processes. Feinste innere Oberflächen für sichere Fertigungsprozesse.

### Surface Treatment

We have decades of experience in mechanical and electrochemical surface treatments and finishes and we offer optimal quality for high purity industrial applications. The spectrum of treatments ranges from pickling to mechanical processes to ultra pure electropolishing with final cleaning in the clean room.

We offer two options for electrochemical processes: Anodic cleaning with a removal of 3 to 5 µm and electropolishing with a material removal of up to 20 µm.

### Bearbeitung von Innenoberflächen

In der mechanischen und elektrochemischen Oberflächenbearbeitung und -veredelung haben wir jahrzehntelange Erfahrung und bieten die optimale Qualität für hochreine industrielle Anwendungen. Das Bearbeitungsspektrum reicht vom Beizen über mechanische Verfahren bis zu hochreinem Elektropolieren mit anschließender Reinigung im Reinraum.

Bei elektrochemischen Verfahren bieten wir zwei Optionen: Anodisches Reinigen mit einem Abtrag von 3 bis 5 µm und Elektropolieren mit einem Materialabtrag von bis zu 20 µm.



### Qualities for Liquids / Qualitäten für Flüssigkeiten

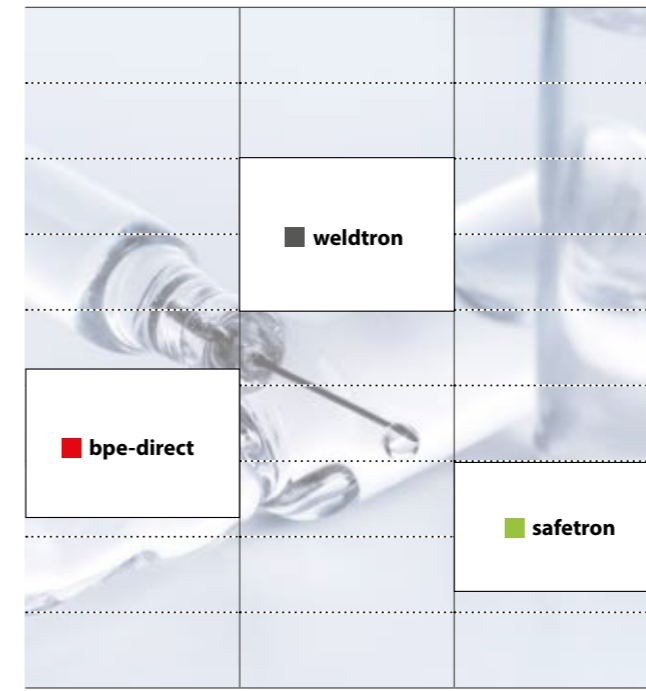

bright finished (SF1)	bright finished (H3o)	bright finished (H4o)
-	anodical cleaned	
electropolished (SF4)	electropolished (HE3o)	electropolished (HE4o)



### Qualities / Qualitäten

### Page / Seite

<b>safetron</b>	6-7
<b>weldtron</b>	8-9
<b>bpe-direct</b>	10-11
General Allgemeines	20-21

### Qualities for Gases / Qualitäten für Gase

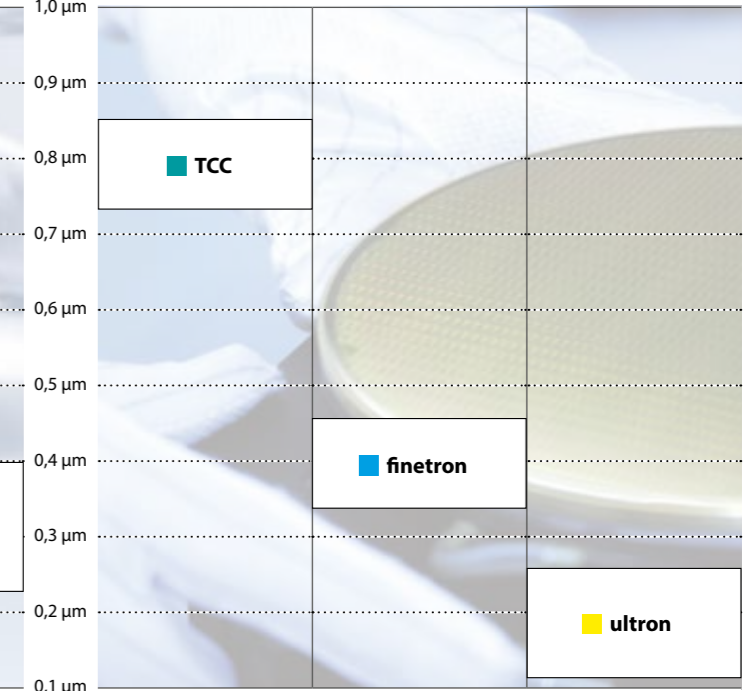

bright finished	bright finished	-
anodical cleaned		-
-	-	electropolished



### Qualities / Qualitäten

### Page / Seite

<b>ultron</b>	12-13
<b>finetron</b>	14-15
<b>TCC</b>	16-17
<b>VSR80</b>	18-19
General Allgemeines	20-21

**safetron**

**liquid applications**

Especially for the  
pharmaceutical industry  
Speziell für Anwendungen  
in der pharmazeutischen Industrie



Particularly corrosion resistant  
with defined ferrite content  $\leq 0.5\%$   
Besonders korrosionsbeständig: Mit einem  
definierten Ferritgehalt von  $\leq 0,5\%$



Designed for the transport  
of sensitive media  
Entwickelt für den Transport sensibler Medien



Available as bright-finished  
and electropolished versions  
Verfügbar in metallblanker und  
elektropolierter Ausführung



**safetron**

**Dimensions / Abmessungen**

**OD TUBING**

acc. to ASTM A269 / A270 and DIN 11866 Series C

1/4" to 6" (0.250 x 0.035 inch to 6.000 x 0.109 inch)

6,35 x 0,89 mm to 152,40 x 2,77 mm

**ISO**

acc. to DIN EN ISO 1127 and DIN 11866 Series B

13,50 x 1,60 mm to 219,10 x 2,60 mm

Other dimensions, e.g. metric, on request.

Weitere Abmessungen (z. B. metrisch) auf Anfrage.

**Materials / Werkstoffe**

1.4435 / UNS S31603 (316L)\*

1.4404 / UNS S31603 (316L)

1.4539 / UNS N08904 (904L)

UNS S31603 (316L)

\*acc. to Basler Norm 2 (BN2) with ferrite content of basic material and longitudinal weld  $\leq 0,5\%$ , for ISO dimensions also circumferential weld  $\leq 0,5\%$  ferrite content, excluding forgings  $\leq 3\%$

gemäß Basler Norm 2 (BN2) mit Ferritgehalt von Grundmaterial und Längsnaht  $\leq 0,5\%$ , ausgenommen Schmiedeteile  $\leq 3\%$

**Hardness equivalent to / Härte entspricht:**

max. 180 HV according to DIN EN ISO 6507-1

max. 90 HRB according to DIN EN ISO 6508-1

**Surfaces / Oberflächen**

**TUBE AND TUBE FITTINGS / ROHRE UND FORMTEILE**

H40\* (bf) Bright finished / Metallblank:  
Ra  $\leq 0,40 \mu\text{m}$  (16  $\mu\text{in}$ )

HE50\* (ep) Electropolished / Elektropoliert:  
Ra  $\leq 0,25 \mu\text{m}$  (10  $\mu\text{in}$ )

\* Hygienic class acc. to DIN 11866 / 11865 / 11864  
Hygieneklassen gemäß DIN 11866 / 11865 / 11864

Orbital welds made in the construction of fittings left as-welded, Ra not defined. T-pieces as per DIN 11865, option „u“. Welds finished after welding on request. Such finishing shall meet the Ra requirements.

Ra-Wert auf der Rundschweißnaht von Formteilen nicht definiert. T-Stücke gemäß DIN 11865, Option „u“. Rundschweißnähte verschliffen mit spezifiziertem Ra-Wert auf Anfrage.

**Surface treatment:**

- Bright finished:  
Cleaning and test procedure ASTM A 632, S3
- Electropolished:  
Procedure acc. to Spec. Doc. 8.4-40/3.2/3.3.2  
Free of oil and grease acc. to CGA G-4.1-2018 and ASTM G93

**Oberflächenbearbeitung:**

- Metallblank:  
Reinigungs- und Prüfverfahren ASTM A 632, S3
- Elektropoliert:  
gemäß Spez. Doc. 8.4-40/3.2/3.3.2  
Öl- und fettfrei gemäß CGA G-4.1-2018 und ASTM G93

Further details page 20-21 / weitere Informationen auf Seite 20-21

Technical terms of delivery | Quality and test procedures | Documentation, packaging and shipping

Technische Lieferbedingungen | Qualitätskontrolle und Prüfverfahren | Dokumentation, Verpackung und Versand

## weldtron

## liquid applications

For pharmaceutical industry  
and biotechnology...

Für Anwendungen in der pharmazeutischen  
Industrie und der Biotechnologie...



... as well as for critical areas  
of cosmetic and food industry

... sowie für sensible Bereiche  
der Kosmetik- und Lebensmittelindustrie



Optimum weldability  
Optimale Verschweißbarkeit



Universal product  
for the transport of liquids

Universalprodukt für den Transport  
von Flüssigkeiten



## weldtron

### Dimensions / Abmessungen

#### OD TUBING

acc. to ASTM A269 / A270 and DIN 11866 Series C

1/4" to 6" (0.250 x 0.035 inch to 6.000 x 0.109 inch)

6,35 x 0,89 mm to 152,40 x 2,77 mm

#### ISO

acc. to DIN EN ISO 1127 and DIN 11866 Series B

13,50 x 1,60 mm to 219,10 x 2,60 mm

#### METRIC

acc. to DIN 11866 Series A

6,00 x 1,00 mm to 154,00 x 2,00 mm

### Materials / Werkstoffe

1.4435 / UNS S31603 (316L)\*

1.4404 / UNS S31603 (316L)

1.4539 / UNS N08904 (904L)

UNS S31603 (316L)

\*acc. to Basler Norm 2 (BN2) with ferrite content of basic material and longitudinal weld  $\leq 0,5\%$ , for ISO dimensions also circumferential weld  $\leq 0,5\%$  ferrite content, excluding forgings  $\leq 3\%$

\*gemäß Basler Norm 2 (BN2) mit Ferritgehalt von Grundmaterial und Längsnaht  $\leq 0,5\%$ , ausgenommen Schmiedeteile  $\leq 3\%$

### Hardness equivalent to / Härte entspricht:

max. 180 HV according to DIN EN ISO 6507-1

max. 90 HRB according to DIN EN ISO 6508-1

### Surfaces / Oberflächen

#### TUBE AND TUBE FITTINGS / ROHRE UND FORMTEILE

H30\* (bf) Bright finished / Metallblank:  
Ra  $\leq 0,80 \mu\text{m}$  (32  $\mu\text{in}$ )

H30\* (ac) Anodical cleaned / Anodisch gereinigt:  
Ra  $\leq 0,80 \mu\text{m}$  (32  $\mu\text{in}$ )

HE30\* (ep) Electropolished / Elektropoliert:  
Ra  $\leq 0,60 \mu\text{m}$  (24  $\mu\text{in}$ )

\* Hygienic class acc. to DIN 11866 / 11865 / 11864  
Hygieneklassen gemäß DIN 11866 / 11865 / 11864

Orbital welds made in the construction of fittings left as-welded, Ra not defined. T-pieces as per DIN 11865, option „u“. Welds finished after welding on request. Such finishing shall meet the Ra requirements.

Ra-Wert auf der Rundschweißnaht von Formteilen nicht definiert. T-Stücke gemäß DIN 11865, Option „u“. Rundschweißnähte verschliffen mit spezifiziertem Ra-Wert auf Anfrage.

#### Surface treatment:

- Bright finished:  
Cleaning and test procedure ASTM A 632, S3
- Anodical cleaned and electropolished:  
Procedure acc. to Spec. Doc. 8.4-40/3.2/3.3.2  
Free of oil and grease acc. to CGA G-4.1-2018 and ASTM G93

#### Oberflächenbearbeitung:

- Metallblank:  
Reinigungs- und Prüfverfahren ASTM A 632, S3
- Anodisch gereinigt und elektropoliert:  
gemäß Spez. Doc. 8.4-40/3.2/3.3.2  
Öl- und fettfrei gemäß CGA G-4.1-2018 und ASTM G93

Further details page 20-21 / weitere Informationen auf Seite 20-21

Technical terms of delivery | Quality and test procedures | Documentation, packaging and shipping

Technische Lieferbedingungen | Qualitätskontrolle und Prüfverfahren | Dokumentation, Verpackung und Versand

**bpe-direct**

**liquid applications**

For pharmaceutical industry  
and biotechnology  
Für Anwendungen in der pharmazeutischen  
Industrie und der Biotechnologie



Electropolished versions  
according to ASME BPE classes  
SF4 to SF6

**Elektropolierte Ausführung  
gemäß ASME BPE Klassen SF4 bis SF6**

Worldwide unique:  
certified for special materials  
such as C22 and AL-6XN

**Weltweit einzigartig:  
zertifiziert für Sonderwerkstoffe  
wie C22 und AL-6XN**



First and only certified  
manufacturer for tubes and  
fittings in Europe

**Europas erster und einziger zertifizierter  
Hersteller für Rohre und Formteile  
nach ASME BPE**



**bpe-direct**

**Dimensions / Abmessungen**

**OD TUBING**

acc. to ASME BPE, Part DT

1/4" to 6" (0,250 x 0,035 inch to 6,000 x 0,109 inch)

6,35 x 0,89 mm to 152,40 x 2,77 mm

**Materials / Werkstoffe**

UNS S31603 (316L)

UNS S31603 (316L) / 1.4404\*

UNS S31603 (316L) / 1.4435\*

UNS N08904 (904L) / 1.4539

UNS N06022 (C22) / 2.4602

UNS N08367 (AL-6XN)

\*Defined sulphur of 0.005 - 0.017%

Definierter Schwefel von 0,005 - 0,017%

**Hardness equivalent to / Härte entspricht:**

max. 180 HV

max. 90 HRB

**Surfaces / Oberflächen**

**TUBE AND TUBE FITTINGS / ROHRE UND FORMTEILE**

**Mechanically polished / Mechanisch poliert\*:**

SF0: No finish requirement

**SF1: Ra max. ≤ 20 µin (0,51 µm) - Standard**

SF2: Ra max. ≤ 25 µin (0,64 µm)

SF3: Ra max. ≤ 30 µin (0,76 µm)

\* Or any other finishing method that meets the Ra(max)  
Oder jede andere Oberflächenbehandlung, die dem Ra(max)  
entspricht

**Electropolished / Elektropoliert:**

**SF4: Ra max. ≤ 15 µin (0,38 µm) - Standard**

SF5: Ra max. ≤ 20 µin (0,51 µm)

SF6: Ra max. ≤ 25 µin (0,64 µm)

**Surface treatment:**

- Mechanically polished\*:

Cleaning and test procedure ASTM A 632, S3

- Electropolished:

Procedure acc. to Spec. Doc. 8.4-40/3.2/3.3.2

Free of oil and grease acc. to CGA G-4.1-2018 and ASTM G93

**Oberflächenbearbeitung:**

- Mechanisch geschliffen:

Reinigungs- und Prüfverfahren ASTM A 632, S3

- Elektropoliert:

gemäß Spez. Doc. 8.4-40/3.2/3.3.2

Öl- und fettfrei gemäß CGA G-4.1-2018 und ASTM G93

**Further details page 20-21 / weitere Informationen auf Seite 20-21**

Technical terms of delivery | Quality and test procedures | Documentation, packaging and shipping

Technische Lieferbedingungen | Qualitätskontrolle und Prüfverfahren | Dokumentation, Verpackung und Versand

**ultron**

**gas applications**

For semiconductor industry  
and fine chemistry  
Für Anwendungen in der Halbleiterindustrie  
und der Feinchemie entwickelt



Wetted surface  
with highest purity  
Höchste Reinheit der Innenoberfläche

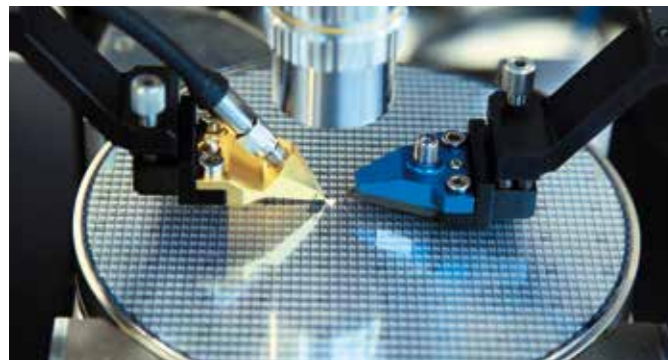

Electropolished  
inner surface  
Elektropolierte Innenoberflächen



Cleanroom  
cleaning and packing  
Reinigung und Verpackung im Reinraum



**ultron**

**Dimensions / Abmessungen**

**OD TUBING**

acc. to ASTM A269 / A632

1/8" to 6" (0.125 x 0.022 inch to 6.000 x 0.109 inch)

3,18 x 0,56 mm\* to 152,40 x 2,77 mm

**PIPE**

acc. to ASTM A312

219,08 x 3,76 mm to 323,85 x 4,75 mm

NPS 8, 10, 12, Schedule 10S

**METRIC**

3,00 x 0,50 mm\* to 35,00 x 1,50 mm

**Surfaces / Oberflächen**

**TUBE AND TUBE FITTINGS / ROHRE UND FORMTEILE**

Ra ≤ 0,25 µm (10 µin)

Ra ≤ 0,13 µm (5 µin) on request / auf Anfrage

Ra ≤ 0,18 µm (7 µin) on request / auf Anfrage

**PIPE AND PIPE FITTINGS**

Ra ≤ 0,51 µm (20 µin) Inner surface / Innenoberfläche

End preparation: square cut

Endenbearbeitung: rechtwinklig geschnitten

The Ra value in the cold worked area of fittings (inner and outer surface) and on the surface of circumferential welds is not defined. For dimensions OD ≤ 5,00 mm roughness is not measured.

Free of oil and grease acc. to CGA G-4.1-2018 and ASTM G93

Ra-Wert im Kaltumformbereich und auf der Rundschweißnaht von Formteilen ist nicht definiert. Für Abmessungen mit Außendurchmesser ≤ 5,00 mm wird der Ra-Wert nicht gemessen.

Öl- und fettfrei gemäß CGA G-4.1-2018 und ASTM G93

**FLEXTRON**

Corrugated hose / Wellrohrschlauch

Ra ≤ 0,60 µm (i/d surface valley / Innenoberfläche Tal)

Ra ≤ 0,40 µm (i/d surface peak / Innenoberfläche Berg)

**Materials / Werkstoffe**

1.4404 / UNS S31603 (316L)

on request / auf Anfrage

UNS S31603 (316L) VIMVAR double melted stainless steel acc. to ASTM A 269/A 632 for OD tubing (Imperial)

UNS S31603 (316L) VIMVAR doppelt geschmolzener Edelstahl nach ASTM A 269/A 632 für OD-Rohre (Imperial)

**Hardness equivalent to / Härte entspricht:**

max. 180 HV according to DIN EN ISO 6507-1

max. 90 HRB according to DIN EN ISO 6508-1

**Cleaning & packing / Reinigung & Verpackung**

Cleanroom Federal Class 10 / ISO Class 4

Reinraum (Federal Class 10 / ISO Klasse 4)

Further details page 20-21 / weitere Informationen auf Seite 20-21

Technical terms of delivery | Quality and test procedures | Documentation, packaging and shipping

Technische Lieferbedingungen | Qualitätskontrolle und Prüfverfahren | Dokumentation, Verpackung und Versand

## finetron

## gas applications

For semiconductor industry  
and fine chemistry

Für Anwendungen in der Halbleiterindustrie  
und der Feinchemie entwickelt



Ideal for the transport  
of pure gases  
Ideal für den Transport von reinen Gasen

Bright finished  
inner surfaces  
Metallblanke Innenoberflächen



Individually cleaned, capped  
and sealed in robust foil  
individuell gereinigt, verkappt  
und in robuster Folie verschweißt

## finetron

### Dimensions / Abmessungen

#### OD TUBING

acc. to ASTM A269 / A632

1/4" to 6" (0.250 x 0.035 inch to 6.000 x 0.109 inch)

6,35 x 0,89 mm to 152,40 x 2,77 mm

#### METRIC

6,00 x 1,00 mm to 35,00 x 1,50 mm

### Surfaces / Oberflächen

#### TUBE AND TUBE FITTINGS / ROHRE UND FORMTEILE

(bf) Bright finished / Metallblank:

OD ≤ 63,50: Ra ≤ 0,40 µm (16 µin)

OD > 63,50: Ra ≤ 0,60 µm (24 µin)

The Ra value in the cold worked area of fittings (inner and outer surface) and on the surface of circumferential welds is not defined. For dimensions OD ≤ 5,00 mm roughness is not measured.

Ra-Wert im Kaltumformbereich und auf der Rundschweißnaht von Formteilen ist nicht definiert. Für Abmessungen mit Außendurchmesser ≤ 5,00 mm wird der Ra-Wert nicht gemessen.

#### Surface treatment:

Bright finished:

Cleaning and test procedure ASTM A 632, S3

Free of oil and grease according to CG A G-4.1-2018 and ASTM G93

#### Oberflächenbearbeitung:

Metallblank:

Reinigungs- und Prüfverfahren ASTM A 632, S3

Öl- und fettfrei gemäß CG A G-4.1-2018 und ASTM G93

### Materials / Werkstoffe

1.4404 / UNS S31603 (316L)

#### Hardness equivalent to / Härte entspricht:

max. 180 HV according to DIN EN ISO 6507-1

max. 90 HRB according to DIN EN ISO 6508-1

Further details page 20-21 / weitere Informationen auf Seite 20-21

Technical terms of delivery | Quality and test procedures | Documentation, packaging and shipping

Technische Lieferbedingungen | Qualitätskontrolle und Prüfverfahren | Dokumentation, Verpackung und Versand



**TCC**

**gas applications**

For semiconductor industry  
as well as measurement and  
control technology

Für Anwendungen in der Halbleiterindustrie  
sowie in der Mess- und Regelungstechnik



TCC: Thermocouple clean  
tubes and fittings

TCC: Thermocouple Clean Rohre und Formteile



Bright finish surface (TCC)  
or anodically cleaned (TCC.1)

Mit metallblanker Oberfläche (TCC)  
sowie anodisch gereinigt (TCC.1)



With excellent  
price-performance ratio

Hervorragendes Preis-Leistungs-Verhältnis



**TCC**

**Dimensions / Abmessungen**

**OD TUBING**

acc. to ASTM A269 / A632

1/8" to 6" (0.125 x 0.022 inch to 6.000 x 0.109 inch)

3,18 x 0,56 mm to 152,40 x 2,77 mm

**PIPE**

acc. to ASTM A312

219,08 x 3,76 mm to 508,00 x 5,54 mm

NPS 8, 10, 12, 16, 20 Schedule 10S

**METRIC**

3,00 x 0,50 mm to 35,00 x 1,50 mm

**Surfaces / Oberflächen**

**TUBE AND TUBE FITTINGS / ROHRE UND FORMTEILE**

**TCC: (bf) Bright finished / Metallblank:**

Ra values for inner surface not defined / nicht definiert  
Ra value ≤ 0,80 µm (32 µin) on request / auf Anfrage

**TCC.1: (ac) Anodical cleaned / Anodisch gereinigt:**

Ra values for inner surface not defined / nicht definiert  
Ra value ≤ 0,80 µm (32 µin) on request / auf Anfrage

**PIPE AND PIPE FITTINGS**

Inner and outer surface is not defined

Innen- und Außenoberfläche ist nicht definiert

End preparation: square cut

Endenbearbeitung: rechtwinklig geschnitten

The Ra value in the cold worked area of fittings (inner and outer surface) and on the surface of circumferential welds is not defined. For dimensions OD ≤ 5,00 mm roughness is not measured.

TCC and TCC.1:

Free of oil and grease according to CG A G-4.1-2018  
and ASTM G93

Ra-Wert im Kaltumformbereich und auf der Rundschweißnaht von Formteilen ist nicht definiert. Für Abmessungen mit Außendurchmesser ≤ 5,00 mm wird der Ra-Wert nicht gemessen.

TCC und TCC.1:

Öl- und fettfrei gemäß CG A G-4.1-2018 und ASTM G93

**Materials / Werkstoffe**

1.4404 / UNS S31603 (316L)

1.4435 / UNS S31603 (316L) acc. to BN2

1.4307

UNS S31603 (316L)

UNS S30403 (304L)

**Hardness equivalent to / Härte entspricht:**

max. 180 HV according to DIN EN ISO 6507-1

max. 90 HRB according to DIN EN ISO 6508-1

Further details page 20-21 / weitere Informationen auf Seite 20-21

Technical terms of delivery | Quality and test procedures | Documentation, packaging and shipping

Technische Lieferbedingungen | Qualitätskontrolle und Prüfverfahren | Dokumentation, Verpackung und Versand

## VSR80

gas applications

Well suited  
for use in laboratories

Besonders für Anwendungen  
in Laboren geeignet



For leak-tight but  
detachable connections  
Für hochdichte, wieder lösbare Verbindungen

Controlled hardness  
for easy installation

Kontrollierte Härte für einfache Installation



VSR80 tubes and mini-ball  
valves - the ideal combination

Verschraubungsrohr VSR80  
und Kugelhähne – die ideale Kombination



## VSR80

### Dimensions / Abmessungen

#### OD TUBING

acc. to ASTM A269 / A632

1/16" to 1" (0.0625 x 0.010 inch to 1.000 x 0.065 inch)

1,59 x 0,25 mm to 25,40 x 1,65 mm

#### METRIC

3,00 x 0,50 mm to 28,00 x 1,50 mm

#### Other dimensions on request

Weitere Abmessungen auf Anfrage

### Materials / Werkstoffe

1.4404 / UNS S31603 (316L)

#### Hardness equivalent to / Härte entspricht:

max. 70 - 90 HRB

### Surfaces / Oberflächen

#### TUBES / ROHRE

Ra values are not defined for the inner surface.  
The outer surface is free of longitudinal and vertical  
scratches with a Ra value  $\leq 1,00 \mu\text{m}$  (40  $\mu\text{in}$ ).

Ra-Werte sind für die Innenoberfläche nicht definiert.  
Die Außenoberflächen sind frei von Längs- und Quer-  
riefen mit einem Ra  $\leq 1,00 \mu\text{m}$  (40  $\mu\text{in}$ ).

### Mini Ball Valves / Mini-Kugelhähne

#### Series 80 and Series 90 / Serie 80 und Serie 90

Clean for Oxygen Service (CFOS), no lubricant,  
cleanroom packed

Für Sauerstoffanwendungen geeignet (CFOS), frei von  
Schmiermittel, Reinraum verpackt

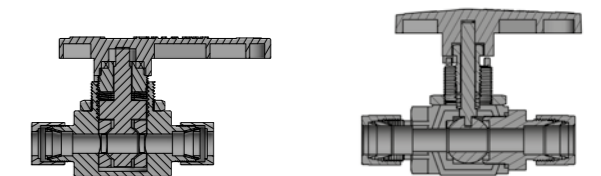

Further information in the brochure **Mini-Ball Valves  
and VSR80 tubes** / Weitere Informationen in der Broschüre  
Mini-Kugelhähne und VSR80-Rohre

Further details page 20-21 / weitere Informationen auf Seite 20-21

Technical terms of delivery | Quality and test procedures | Documentation, packaging and shipping

Technische Lieferbedingungen | Qualitätskontrolle und Prüfverfahren | Dokumentation, Verpackung und Versand

## Quality and test procedures

Qualitätskontrolle und Prüfverfahren

	ultron	finetron	TCC	VSR 80	safetron	weldtron	bpe-direct
Verification of basic test certificate / Vorzeugniskontrolle	■	■	■	■	■	■	■
Visual inspection / Visuelle Prüfung	■	■	■	■	■	■	■
Endoscopic inspection of bright finished tubes / Endoskopie metallblanker Rohre	■	■	■		■	■	■
Verification of dimensions / Baumaßkontrolle	■	■	■	■	■	■	■
Roughness measurements/ Rauheitsmessung	■	■	■		■	■	■
Conductivity test (DI water) / Leitfähigkeitsmessung (deionisiertes Wasser)	■						
TOC-measurement of DI water / TOC-Messung (deionisiertes Wasser)	■						
Particle measurements / Partikelmessung	■						
Scanning Electron Microscope (SEM) / Raster-Elektronen-Mikroskop (REM)	■						
X-ray Photoelectron Spectroscopy XPS / Electron Spectroscopy for Chemical Analysis (ESCA)	■						
Auger analysis (AES) / Auger-Analyse (AES)	■						
δ ferrite measurement (1.4435 BN2 / 316L) / δ-Ferrit-Messung (1.4435 BN2 / 316L)					■	■	

## Technical terms of delivery

### Manufacture and testing

ASTM A 269 / A 632 / A 312 (Pipe),  
 DIN EN 10217-7 / 10216-5  
 Length 5900 - 6090 mm,  
 max. 10% short lengths of min. 3000 mm

Length for electropolished tubes OD ≤ 5,00 mm  
 will be 2950 ± 50 mm.

### End preparation

prepared for orbital welding

### Marking always with

DOCKWEILER | DW-Number  
 Dimension | Material | Heat number

Tubes and fittings are permanently marked  
 Fittings are needle or laser marked.

## Technische Lieferbedingungen

### Herstellung und Prüfung

ASTM A 269 / A 632 / A 312 (Pipe),  
 DIN EN 10217-7 / 10216-5  
 Länge 5900 - 6090 mm,  
 max. 10% Kurzlängen von min. 3000 mm

Bei elektropolierten Rohren mit Außendurchmesser  
 ≤ 5,00 mm beträgt die Länge 2950 ± 50 mm

### Endenvorbereitung

vorbereitet zum Orbitalschweißen

### Kennzeichnung erfolgt immer mit

DOCKWEILER | DW-Nummer  
 Abmessung | Werkstoff | Schmelznummer

Rohre und Formteile sind dauerhaft gekennzeichnet  
 Formteile mit Nadel- oder Lasergravur

## Documentation, Packaging and Shipping

Dokumentation, Verpackung und Versand

	ultron	finetron	TCC	VSR 80	safetron	weldtron	bpe-direct
<b>Documentation / Dokumentation</b>							
Dockweiler Inspection Certificate 3.1 according to EN 10204 Dockweiler Abnahmeprüfzeugnis 3.1 gemäß EN 10204	■	■	■	■	■	■	■
WebCert online documentation optional Online-Dokumentation über WebCert optional möglich	■	■	■	■	■	■	■
<b>Packaging / Verpackung</b>							
Batch label on the foil contains the detailed quality information Chargen-Etikett auf Folienverpackung mit detailliertem Qualitätshinweis	■	■	■		■	■	■
Tubes filled with 99.999% N2 Rohre gefüllt mit 99.999% N2	■						
Bright finished tubes and fittings are closed with transparent PE caps Metallblanker Rohre und Formteile mit transparenten PE-Kappen verschlossen		■	■		■	■	■
304L tubes and fittings are closed with red PE caps 304L Rohre und Formteile mit roten PE-Kappen verschlossen			■				
Closed with PA/PE squares and yellow PE caps, sleeved and sealed in PE Verschlossen mit gelben PE-Kappen und in PA/PE Folien, einzeln in Folie eingeschweißt	■		■		EP only	EP only	EP only
Tubes and fittings are sealed in a bundle in PE foil Rohre und Formteile gebündelt in PE-Folie verpackt			■				
Tubes and fittings individually sealed in PE foil Rohre und Formteile einzeln in PE-Folie verpackt	■	■	■		EP only	EP only	EP only
All products double sleeved Alle Produkte doppelt in Folie verpackt	■						
<b>Shipping / Verpackung</b>							
Delivery of tubes in tubular container or wooden crates Versand von Rohren in Köchern oder Kisten	■	■	■	■	■	■	■
Fittings in strong cardboard box or crates with shock-absorbing filler Formteilen stoßgesichert in festem Karton oder Kisten	■	■	■		■	■	■

# TUBES ROHRE



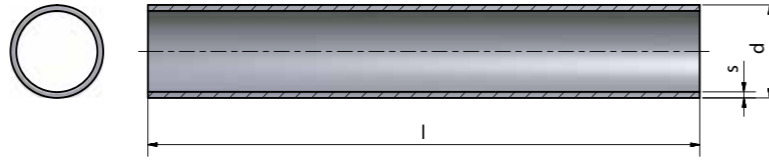

	ultron	finetron	TCC	VSR 80	safetron	weldtron	bpe-direct	Imperial / DIN 11866	d / s	Weight Gewicht
	●	●	●	●	●	●	●	Inch / Zoll	mm	kg / m
	●		●	●				1/8	3,18 x 0,56	0,0368
	●	●	●	●	●	●	●	1/4	6,35 x 0,89	0,1241
	●	●	●	●	●	●	●	3/8	9,53 x 0,89	0,1966
	●	●	●	●				1/2	12,70 x 1,24**	0,3511
	●	●	●	●	x	x	x ●	1/2	12,70 x 1,65	0,4571
	●	●	x ●	●				3/4	19,05 x 1,24**	0,5453
	●	●	x ●	●	x	x	x ●	3/4	19,05 x 1,65	0,7198
	●	●	x ●	●	x	x	x	1	25,40 x 1,65	0,9824
	x	x	x		x	x	x	1 1/2	38,10 x 1,65	1,5077
	x	x	x		x	x	x	2	50,80 x 1,65	2,0331
	x	x	x		x	x	x	2 1/2	63,50 x 1,65	2,5585
	x	x	x		x	x	x	3	76,20 x 1,65	3,0838
	x	x	x		x	x	x	4	101,60 x 2,11	5,2627
	x	x	x		x	x	x	6	152,40 x 2,77	10,3909

	ultron	finetron	TCC	VSR 80	safetron	weldtron	bpe-direct	PIPE NPS Schedule 10S	d / s	Weight Gewicht
	●	●	●	●	●	●	●	DN / NPS	mm	kg / m
	x	x	x					6*	168,28 x 3,40	14,0400
	x	x	x					8	219,08 x 3,76	20,2700
	x	x	x					10	273,05 x 4,19	28,2100
	x	x	x					12	323,85 x 4,57	36,5400
			x					16	406,40 x 4,78	48,0700
			x					20	508,00 x 5,54	69,9500

● = seamless (standard programme) / nahtlos (Standard)  
x = welded (standard programme) / geschweisst (Standard)

Further dimensions on request. Subject to alteration.  
Weitere Abmessungen auf Anfrage. Technische Änderungen vorbehalten.

\* on request / auf Anfrage  
\*\* Wall thickness does not comply with DIN 11866 /  
Wandstärke entspricht nicht der DIN 11866

	ultron	finetron	TCC	VSR 80	safetron	weldtron	bpe-direct	ISO/DIN 11866	d / s	Weight Gewicht
	●	●	●	●	●	●	●	DN / NW	mm	kg/m
					●	●		8	13,50 x 1,60	0,4773
					●	●		10	17,20 x 1,60	0,6257
					x ●	x ●		15	21,30 x 1,60	0,7902
					x ●	x ●		20	26,90 x 1,60	1,0148
					x	x		25	33,70 x 2,00	1,5894
					x	x		32	42,40 x 2,00	2,0257
					x	x		40	48,30 x 2,00	2,3215
					x	x		50	60,30 x 2,00	2,9232
					x	x		65	76,10 x 2,00	3,7154
					x	x		80	88,90 x 2,30	4,9934
					x	x		100	114,30 x 2,30	6,4580
					x	x		150	168,30 x 2,60	10,8007
					x	x		200	219,10 x 2,60	14,1119

	ultron	finetron	TCC	VSR 80	safetron	weldtron	bpe-direct	Metric / DIN 11866	d / s	Weight Gewicht
	●	●	●	●	●	●	●	DN / NW	mm	kg/m
	●		●	●					3,00 x 0,50	0,0313
	●	●	●	●		●		4	6,00 x 1,00	0,1254
	●	●	●	●		●		6	8,00 x 1,00	0,1755
	●	●	●	●		●		8	10,00 x 1,00	0,2256
	●	●	●	●		●		10	12,00 x 1,00	0,2758
								10	13,00 x 1,50	0,4325
								15	18,00 x 1,50	0,6205
								15	19,00 x 1,50	0,6581
								20	23,00 x 1,50	0,8085
								25	28,00 x 1,50	0,9965
								25	29,00 x 1,50	1,0341
								32	35,00 x 1,50	1,2598
	x	x	x					40	41,00 x 1,50	1,4854
								50	53,00 x 1,50	1,9367
								65	70,00 x 2,00	3,4095
								80	85,00 x 2,00	4,1616
								100	104,00 x 2,00	5,1143
								150	154,00 x 2,00	7,6213

● = seamless (standard programme) / nahtlos (Standard)  
x = welded (standard programme) / geschweisst (Standard)

Further dimensions on request. Subject to alteration.  
Weitere Abmessungen auf Anfrage. Technische Änderungen vorbehalten.

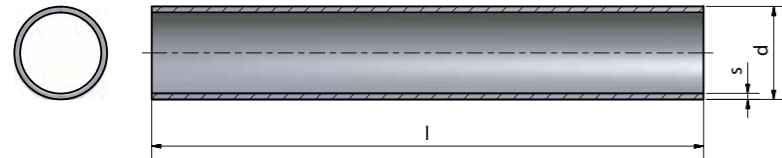

d / s	Weight Gewicht	d / s	Weight Gewicht
mm	kg/m	mm	kg/m
0,30 x 0,06	0,0004	5,00 x 1,00	0,1002
0,80 x 0,20	0,0030	6,00 x 0,50	0,0689
1,20 x 0,10	0,0028	6,00 x 1,00	0,1252
1,20 x 0,20	0,0050	6,00 x 1,50	0,1690
1,59 x 0,25	0,0084	6,35 x 0,89	0,1240
1,59 x 0,30	0,0097	7,00 x 0,50	0,0814
1,59 x 0,40	0,0119	8,00 x 0,50	0,0939
1,59 x 0,45	0,0128	8,00 x 1,00	0,1753
1,59 x 0,59	0,0148	8,00 x 1,50	0,2441
2,00 x 0,20	0,0090	9,53 x 0,89	0,1925
2,00 x 0,40	0,0160	9,53 x 1,65	0,3256
2,00 x 0,50	0,0188	10,00 x 0,50	0,1189
3,18 x 0,56	0,0367	10,00 x 1,00	0,2254
3,18 x 0,71	0,0432	12,00 x 0,20	0,0591
4,00 x 0,50	0,0438	12,00 x 2,00	0,5008
4,00 x 1,00	0,0751		

Further dimensions on request. Subject to alteration.  
Weitere Abmessungen auf Anfrage. Technische Änderungen vorbehalten.

These dimensions are only a selection of instrumentation and capillary tubes and not all are available from stock. These tubes are available in various alloys (e.g. 304L, 316L, 316 Ti) and specifications (hard as drawn, annealed). Further dimensions and materials on request.

Diese Abmessungen stellen lediglich eine Auswahl dar und sind nicht alle im Lagerprogramm enthalten. Instrumentierungs- und Kapillarrohre können in verschiedenen Legierungen (z. B. in 304L, 316L, 316Ti) und Ausführungen (geglüht, hartgezogen) geliefert werden. Weitere Abmessungen und Materialien auf Anfrage.

ultron*	finetron	TCC	VSR 80	safetron	weldtron	bpe-direct
•		•				
•		•				
•		•				
•		•				

ultron*	finetron	TCC	VSR 80	safetron	weldtron	bpe-direct
•		•				
•		•				

• = seamless (standard programme) / nahtlos (Standard)  
\* = The length is 30 m / Die Länge beträgt 30 m

Further dimensions on request. Subject to alteration.  
Weitere Abmessungen auf Anfrage. Technische Änderungen vorbehalten.

Imperial	d / s	Weight Gewicht
Inch / Zoll	mm	kg / m
1/8	3,18 x 0,56	0,0368
1/4	6,35 x 0,89	0,1241
3/8	9,53 x 0,89	0,1966
1/2	12,70 x 1,24**	0,3511

Metric	d / s	Weight Gewicht
DN / NPS	mm	kg / m
-	3,00 x 0,50	0,0173
4	6,00 x 1,00	0,1256

\*\* Wall thickness does not comply with DIN 11866 /  
Wandstärke entspricht nicht der DIN 11866

# ELBOWS BÖGEN



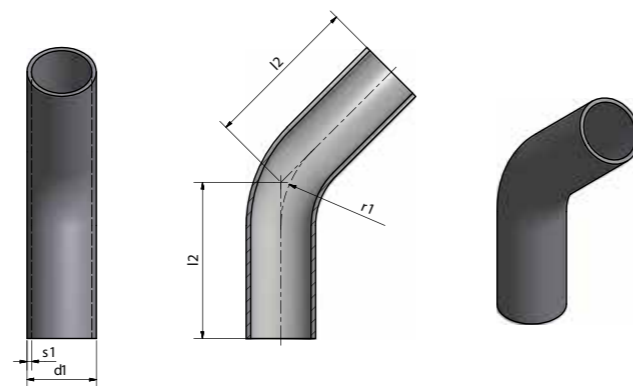

ultron	finetron	TCC	safetron	weldtron	bpe-direct
•	•	•	•	•	•
•	•	•	•	•	•
•	•	•	•	•	•
•	•	•	•	•	•
•	•	•	•	•	•
•	•	•	•	•	•
•	•	•	•	•	•
•	•	•	•	•	•
•	•	•	•	•	•
•	•	•	•	•	•
•	•	•	•	•	•
•	•	•	•	•	•
•	•	•	•	•	•
•	•	•	•	•	•
•	•	•	•	•	•
•	•	•	•	•	•
•	•	•	•	•	•

Imperial / DIN 11865	d1	s1	l2	r1
Inch / Zoll	mm			
1/4	6,35	0,89	50,80	14,30
3/8	9,53	0,89	50,80	28,60
1/2	12,70	1,24**	57,20	27,00
1/2	12,70	1,65	57,20	28,60
3/4	19,05	1,24**	57,20	26,00
3/4	19,05	1,65	57,20	28,60
1	25,40	1,65	57,20	38,10
1 1/2	38,10	1,65	63,50	57,20
2	50,80	1,65	76,20	76,20
2 1/2	63,50	1,65	85,70	95,30
3	76,20	1,65	92,10	114,30
4	101,60	2,11	114,30	152,40
6	152,40	2,77	158,80	228,60
6*	152,40	2,77	222,25	228,60

ultron	finetron	TCC	safetron	weldtron	bpe-direct
•	•	•	•	•	•
•	•	•	•	•	•
•	•	•	•	•	•
•	•	•	•	•	•
•	•	•	•	•	•
•	•	•	•	•	•
•	•	•	•	•	•
•	•	•	•	•	•
•	•	•	•	•	•
•	•	•	•	•	•
•	•	•	•	•	•
•	•	•	•	•	•
•	•	•	•	•	•
•	•	•	•	•	•
•	•	•	•	•	•
•	•	•	•	•	•
•	•	•	•	•	•

ISO / DIN 11865	d1	s1	l2	r1
DN / NW	mm			
8	13,50	1,60	33,30	20,00
10	17,20	1,60	36,60	28,00
15	21,30	1,60	37,40	30,00
20	26,90	1,60	51,80	28,50
25	33,70	2,00	55,70	38,00
32	42,40	2,00	59,70	47,50
40	48,30	2,00	63,60	57,00
50	60,30	2,00	71,50	76,00
65	76,10	2,00	94,40	95,00
80	88,90	2,30	102,40	114,50
100	114,30	2,30	118,20	152,50
150*	168,30*	2,60	94,70	228,50
150*	168,30*	2,60	149,70	228,50

ultron	finetron	TCC	safetron	weldtron	bpe-direct
•	•	•	•	•	•
•	•	•	•	•	•
•	•	•	•	•	•
•	•	•	•	•	•
•	•	•	•	•	•
•	•	•	•	•	•
•	•	•	•	•	•
•	•	•	•	•	•
•	•	•	•	•	•
•	•	•	•	•	•
•	•	•	•	•	•
•	•	•	•	•	•
•	•	•	•	•	•
•	•	•	•	•	•
•	•	•	•	•	•
•	•	•	•	•	•
•	•	•	•	•	•
•	•	•	•	•	•
•	•	•	•	•	•
•	•	•	•	•	•
•	•	•	•	•	•
•	•	•	•	•	•
•	•	•	•	•	•

Metric / DIN 11865	d1	s1	l2	r1
DN / NW	mm			
4	6,00	1,00	32,10	16,00
6	8,00	1,00	32,10	13,50
6	8,00	1,00	32,10	24,00
8	10,00	1,00	33,30	20,00
8	10,00	1,00	33,30	24,00
10	12,00	1,00	35,80	26,00
10	13,00	1,50	35,80	26,00
15	18,00	1,50	35,80	26,00
15	19,00	1,50	39,50	35,00
20	23,00	1,50	41,60	40,00
25	28,00	1,50	60,70	50,00
25	29,00	1,50	60,70	50,00
32	35,00	1,50	62,80	55,00
40	41,00	1,50	64,90	60,00
50	53,00	1,50	69,00	70,00
65	70,00	2,00	73,10	80,00
80	85,00	2,00	92,30	90,00
100	104,00	2,00	96,40	100,00
150	154,00	2,00	193,20	225,00

Further dimensions on request. Subject to alteration.  
Weitere Abmessungen auf Anfrage. Technische Änderungen vorbehalten.

Further dimensions on request. Subject to alteration.  
Weitere Abmessungen auf Anfrage. Technische Änderungen vorbehalten.

\* on request / auf Anfrage  
\*\* Wall thickness does not comply with DIN 11865 / Wandstärke entspricht nicht der DIN 11865



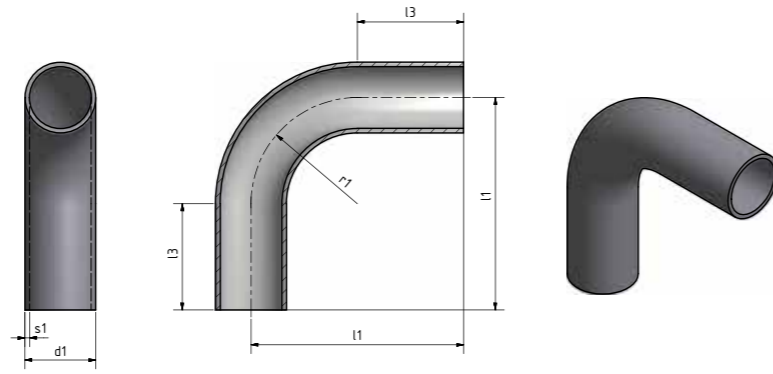

**Imperial /  
DIN 11865**

	d1	s1	l1	l3	r1
<b>Inch / Zoll</b>	<b>mm</b>				
1/4	6,35	0,89	66,70	52,40	14,30
3/8	9,53	0,89	66,70	38,10	28,60
1/2	12,70	1,24**	76,20	49,20	27,00
1/2	12,70	1,65	76,20	47,60	28,60
3/4	19,05	1,24**	76,20	50,20	26,00
3/4	19,05	1,65	76,20	47,60	28,60
1	25,40	1,65	76,20	38,10	38,10
1 1/2	38,10	1,65	95,30	38,10	57,20
2	50,80	1,65	120,70	44,50	76,20
2 1/2	63,50	1,65	139,70	44,40	95,30
3	76,20	1,65	158,80	44,50	114,30
4	101,60	2,11	203,20	50,80	152,40
6	152,40	2,77	292,10	63,50	228,60
6*	152,4*	2,77	355,60	127,00	228,60

**ISO /  
DIN 11865**

	d1	s1	l1	l3	r1
<b>DN / NW</b>	<b>mm</b>				
8	13,50	1,60	45,00	25,00	20,00
10	17,20	1,60	53,00	25,00	28,00
15	21,30	1,60	55,00	25,00	30,00
20	26,90	1,60	68,50	40,00	28,50
25	33,70	2,00	78,00	40,00	38,00
32	42,40	2,00	87,50	40,00	47,50
40	48,30	2,00	97,00	40,00	57,00
50	60,30	2,00	116,00	40,00	76,00
65	76,10	2,00	150,00	55,00	95,00
80	88,90	2,30	169,50	55,00	114,50
100	114,30	2,30	207,50	55,00	152,50

\* on request / auf Anfrage  
\*\* Wall thickness does not comply with DIN 11865 / Wandstärke entspricht nicht der DIN 11865

ultron	finetron	TCC	safetron	weldtron	bpe-direct
•	•	•	•	•	•
•	•	•	•	•	•
•	•	•	•	•	•
•	•	•	•	•	•
•	•	•	•	•	•
•	•	•	•	•	•
•	•	•	•	•	•
•	•	•	•	•	•
•	•	•	•	•	•
•	•	•	•	•	•
•	•	•	•	•	•
•	•	•	•	•	•
•	•	•	•	•	•
•	•	•	•	•	•
•	•	•	•	•	•
•	•	•	•	•	•
•	•	•	•	•	•
•	•	•	•	•	•
•	•	•	•	•	•

ultron	finetron	TCC	safetron	weldtron	bpe-direct
			•	•	
			•	•	
			•	•	
			•	•	
			•	•	
			•	•	
			•	•	
			•	•	
			•	•	
			•	•	
			•	•	
			•	•	
			•	•	
			•	•	
			•	•	
			•	•	
			•	•	
			•	•	
			•	•	

Further dimesions on request. Subject to alteration.  
Weitere Abmessungen auf Anfrage. Technische Änderungen vorbehalten.

ultron	finetron	TCC	safetron	weldtron	bpe-direct
•	•	•		•	
•	•	•		•	
•	•	•			
•	•	•			
•	•	•		•	
•	•	•			
•	•	•			
•	•	•			
•	•	•		•	
•	•	•			
•	•	•			
•	•	•			
•	•	•		•	
•	•	•			
•	•	•			
•	•	•			
•	•	•			
•	•	•			
•	•	•		•	
•	•	•			
•	•	•			
•	•	•			

Further dimesions on request. Subject to alteration.  
Weitere Abmessungen auf Anfrage. Technische Änderungen vorbehalten.

**Metric /  
DIN 11865**

	d1	s1	l1	l3	r1
<b>DN / NW</b>	<b>mm</b>				
4	6,00	1,00	40,00	24,00	16,00
6	8,00	1,00	45,00	21,00	24,00
6*	8,00	1,00	45,00	25,00	20,00
8	10,00	1,00	45,00	25,00	20,00
8*	10,00	1,00	50,00	25,00	25,00
10	12,00	1,00	51,00	25,00	26,00
10	13,00	1,50	51,00	25,00	26,00
15	18,00	1,50	51,00	25,00	26,00
15	19,00	1,50	60,00	25,00	35,00
20	23,00	1,50	65,00	25,00	40,00
25	28,00	1,50	90,00	40,00	50,00
25	29,00	1,50	90,00	40,00	50,00
32	35,00	1,50	95,00	40,00	55,00
40	41,00	1,50	100,00	40,00	60,00
50	53,00	1,50	110,00	40,00	70,00
65	70,00	2,00	120,00	40,00	80,00
80	85,00	2,00	145,00	55,00	90,00
100	104,00	2,00	155,00	55,00	100,00
150	154,00	2,00	325,00	100,00	225,00

\* Additional size different from DIN 11865  
Zusätzliches Maß abweichend von der DIN 11865

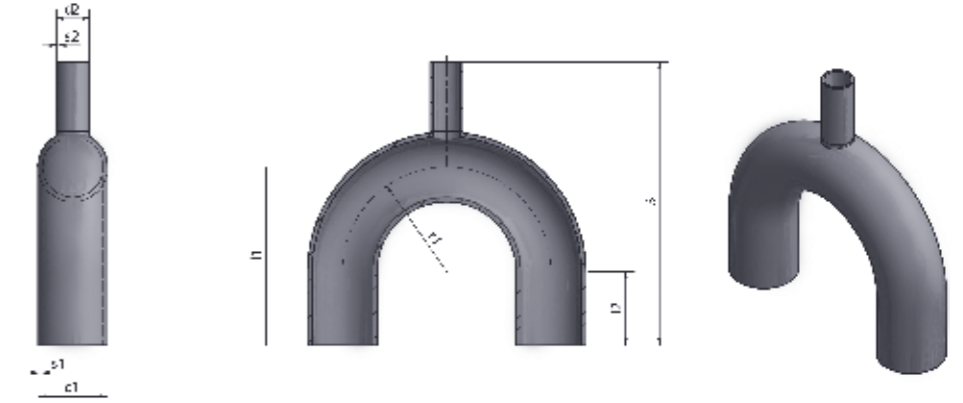
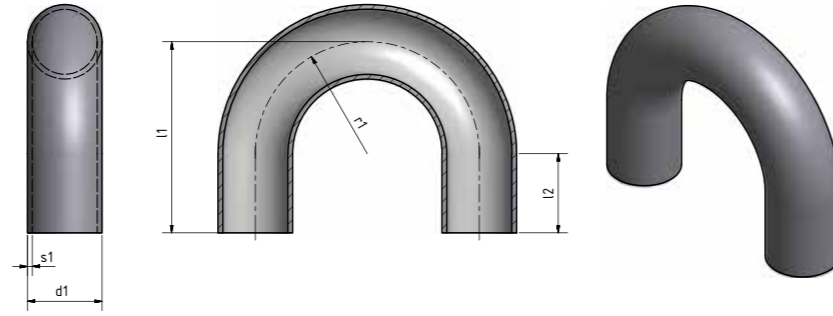

ultron	finetron	TCC	safetron	weldtron	bpe-direct
					•
					•
					•
					•
					•
					•
					•
					•
					•
					•
					•
					•
					•
					•
					•

Imperial	d1	s1	l1	l2	r1
Inch / Zoll	mm				
1/4	6,35	0,89	66,70	9,55	57,15
3/8	9,53	0,89	66,70	9,55	57,15
1/2	12,70	1,65	76,20	19,05	57,15
3/4	19,05	1,65	76,20	19,05	57,15
1	25,40	1,65	76,20	38,10	38,10
1 1/2	38,10	1,65	114,30	57,15	57,15
2	50,80	1,65	127,00	50,80	76,20
2 1/2	63,50	1,65	146,10	50,85	95,25
3	76,20	1,65	165,10	50,80	114,30
4	101,60	2,11	215,90	63,50	152,40
6	152,40	2,77	292,10	63,50	228,60

safetron	weldtron	bpe-direct
		•
		•
		•
		•
		•
		•
		•
		•
		•
		•
		•
		•
		•
		•
		•
		•
		•
		•
		•
		•
		•
		•
		•
		•
		•
		•
		•

Imperial	d1	s1	d2	s2	l1	l2	l3	r1
Inch / Zoll	mm							
1/2" x 1/2"	12,70	1,65	12,70	1,65	76,20	19,05	38,10	57,15
3/4" x 1/2"	19,05	1,65	12,70	1,65	76,20	19,05	38,10	57,15
3/4" x 3/4"	19,05	1,65	19,05	1,65	76,20	19,05	38,10	57,15
1" x 1/2"	25,40	1,65	12,70	1,65	76,20	38,10	38,10	38,10
1" x 3/4"	25,40	1,65	19,05	1,65	76,20	38,10	38,10	38,10
1" x 1"	25,40	1,65	25,40	1,65	76,20	38,10	38,10	38,10
1 1/2" x 1/2"	38,10	1,65	12,70	1,65	114,30	57,15	38,10	57,15
1 1/2" x 1/2"	38,10	1,65	12,70	1,65	114,30	57,15	38,10	57,15
1 1/2" x 3/4"	38,10	1,65	19,05	1,65	114,30	57,15	38,10	57,15
1 1/2" x 1"	38,10	1,65	25,40	1,65	114,30	57,15	38,10	57,15
1 1/2" x 1 1/2"	38,10	1,65	38,10	1,65	114,30	57,15	38,10	57,15
2" x 1/2"	50,80	1,65	12,70	1,65	127,00	50,80	38,10	76,20
2" x 3/4"	50,80	1,65	19,05	1,65	127,00	50,80	38,10	76,20
2" x 1"	50,80	1,65	25,40	1,65	127,00	50,80	38,10	76,20
2" x 1 1/2"	50,80	1,65	38,10	1,65	127,00	50,80	38,10	76,20
2 1/2" x 1/2"	63,50	1,65	12,70	1,65	146,10	50,85	38,10	95,25
2 1/2" x 3/4"	63,50	1,65	19,05	1,65	146,10	50,85	38,10	95,25
2 1/2" x 1"	63,50	1,65	25,40	1,65	146,10	50,85	38,10	95,25
2 1/2" x 1 1/2"	63,50	1,65	38,10	1,65	146,10	50,85	38,10	95,25
3" x 1/2"	76,20	1,65	12,70	1,65	165,10	50,80	44,45	114,30
3" x 3/4"	76,20	1,65	19,05	1,65	165,10	50,80	44,45	114,30
3" x 1"	76,20	1,65	25,40	1,65	165,10	50,80	44,45	114,30
3" x 1 1/2"	76,20	1,65	38,10	1,65	165,10	50,80	44,45	114,30

Further dimensions and qualities on request. Subject to alteration.  
Weitere Abmessungen und Qualitäten auf Anfrage.  
Technische Änderungen vorbehalten.

Further dimensions and qualities on request. Subject to alteration.  
Weitere Abmessungen und Qualitäten auf Anfrage. Technische Änderungen vorbehalten.



**30° ELBOWS**  
30° BÖGEN



**60° ELBOWS**  
60° BÖGEN



**88° ELBOWS**  
88° BÖGEN



**92° ELBOWS**  
92° BÖGEN



**90° POINT-OF-USE  
ELBOWS**  
90° BÖGEN  
MIT ABGANG

# T-PIECES T-STÜCKE



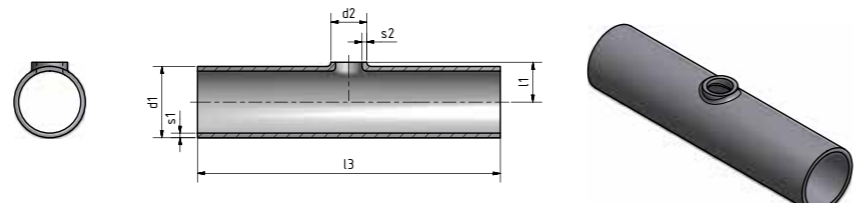

ultron	finetron	TCC	safetron	weldtron	bpe-direct
			•	•	
			•	•	
			•	•	
			•	•	
			•	•	
			•	•	
			•	•	
			•	•	
			•	•	
			•	•	
			•	•	
			•	•	
			•	•	
			•	•	
			•	•	
			•	•	
			•	•	
			•	•	
			•	•	
			•	•	
			•	•	
			•	•	
			•	•	
			•	•	
			•	•	
			•	•	

Imperial / DIN 11865	d1 x d2	s1	s2	l3	l1
Inch / Zoll	mm				
1/2 x 1/2	12,70 x 12,70	1,65	1,65	95,20	11,35
3/4 x 1/2	19,05 x 12,70	1,65	1,65	101,60	11,03
3/4 x 3/4	19,05 x 19,05	1,65	1,65	101,60	11,03
1 x 1/2	25,40 x 12,70	1,65	1,65	108,00	14,20
1 x 3/4	25,40 x 19,05	1,65	1,65	108,00	14,20
1 x 1	25,40 x 25,40	1,65	1,65	108,00	14,20
1 1/2 x 3/4	38,10 x 19,05	1,65	1,65	120,60	20,55
1 1/2 x 1	38,10 x 25,40	1,65	1,65	120,60	20,55
1 1/2 x 1 1/2	38,10 x 38,10	1,65	1,65	120,60	21,05
2 x 1	50,80 x 25,40	1,65	1,65	146,00	26,90
2 x 1 1/2	50,80 x 38,10	1,65	1,65	146,00	27,40
2 x 2	50,80 x 50,80	1,65	1,65	146,00	28,90
2 1/2 x 1 1/2	63,50 x 38,10	1,65	1,65	158,80	33,75
2 1/2 x 2	63,50 x 50,80	1,65	1,65	158,80	35,25
2 1/2 x 2 1/2	63,50 x 63,50	1,65	1,65	158,80	35,25
3 x 1	76,20 x 25,40	1,65	1,65	171,50	40,60
3 x 1 1/2	76,20 x 38,10	1,65	1,65	171,50	40,10
3 x 2	76,20 x 50,80	1,65	1,65	171,50	41,60
3 x 2 1/2	76,20 x 63,50	1,65	1,65	171,50	41,60
3 x 3	76,20 x 76,20	1,65	1,65	171,40	43,10
4 x 1 1/2	101,60 x 38,10	2,11	1,65	209,60	53,80
4 x 2	101,60 x 50,80	2,11	1,65	209,60	54,30
4 x 2 1/2	101,60 x 63,50	2,11	1,65	209,60	54,30
4 x 3	101,60 x 76,20	2,11	1,65	209,60	55,80
4 x 4	101,60 x 101,60	2,11	1,65	209,60	56,80

Further dimensions on request. Subject to alteration.  
It depends on the dimensions, which manufacturing process will be used.

Weitere Abmessungen auf Anfrage. Technische Änderungen vorbehalten.  
Je nach Abmessung können unterschiedliche Fertigungsverfahren angewandt werden.

ultron	finetron	TCC	safetron	weldtron	bpe-direct
			•	•	
			•	•	
			•	•	
			•	•	
			•	•	
			•	•	
			•	•	
			•	•	
			•	•	
			•	•	
			•	•	
			•	•	
			•	•	
			•	•	
			•	•	
			•	•	
			•	•	
			•	•	
			•	•	
			•	•	
			•	•	
			•	•	
			•	•	
			•	•	
			•	•	
			•	•	
			•	•	
			•	•	
			•	•	
			•	•	
			•	•	
			•	•	
			•	•	
			•	•	
			•	•	
			•	•	
			•	•	
			•	•	
			•	•	
			•	•	
			•	•	
			•	•	
			•	•	

Further dimensions on request. Subject to alteration.  
It depends on the dimensions, which manufacturing process will be used.

ISO / DIN 11865	d1 x d2	s1	s2	l3	l1
DN / NW	mm				
8 x 8	13,50 x 13,50	1,60	1,60	64,00	11,75
10 x 8	17,20 x 13,50	1,60	1,60	68,00	10,10
10 x 10	17,20 x 17,20	1,60	1,60	68,00	10,10
15 x 8	21,30 x 13,50	1,60	1,60	72,00	12,15
15 x 10	21,30 x 17,20	1,60	1,60	72,00	12,15
15 x 15	21,30 x 21,30	1,60	1,60	72,00	12,15
20 x 10	26,90 x 17,20	1,60	1,60	110,00	14,95
20 x 15	26,90 x 21,30	1,60	1,60	110,00	14,95
20 x 20	26,90 x 26,90	1,60	1,60	110,00	14,95
25 x 15	33,70 x 21,30	2,00	1,60	120,00	18,35
25 x 20	33,70 x 26,90	2,00	1,60	120,00	18,35
25 x 25	33,70 x 33,70	2,00	2,00	120,00	18,35
32 x 15	42,40 x 21,30	2,00	1,60	130,00	22,70
32 x 20	42,40 x 26,90	2,00	1,60	130,00	22,70
32 x 25	42,40 x 33,70	2,00	2,00	130,00	22,70
32 x 32	42,40 x 42,40	2,00	2,00	130,00	23,20
40 x 15	48,30 x 21,30	2,00	1,60	130,00	25,65
40 x 20	48,30 x 26,90	2,00	1,60	130,00	25,65
40 x 25	48,30 x 33,70	2,00	2,00	130,00	25,65
40 x 32	48,30 x 42,40	2,00	2,00	130,00	26,15
40 x 40	48,30 x 48,30	2,00	2,00	130,00	26,65
50 x 20	60,30 x 26,90	2,00	1,60	180,00	32,65
50 x 25	60,30 x 33,70	2,00	2,00	180,00	31,65
50 x 32	60,30 x 42,40	2,00	2,00	180,00	32,15
50 x 40	60,30 x 48,30	2,00	2,00	180,00	32,65
50 x 50	60,30 x 60,30	2,00	2,00	180,00	33,65
65 x 25	76,10 x 33,70	2,00	2,00	220,00	40,55
65 x 32	76,10 x 42,40	2,00	2,00	220,00	40,05
65 x 40	76,10 x 48,30	2,00	2,00	220,00	40,55
65 x 50	76,10 x 60,30	2,00	2,00	220,00	41,55
65 x 65	76,10 x 76,10	2,00	2,00	220,00	43,05
80 x 32	88,90 x 42,40	2,30	2,00	260,00	46,95
80 x 40	88,90 x 48,30	2,30	2,00	260,00	46,95
80 x 50	88,90 x 60,30	2,30	2,00	260,00	47,95
80 x 65	88,90 x 76,10	2,30	2,00	260,00	49,45
80 x 80	88,90 x 88,90	2,30	2,30	260,00	49,45
100 x 50	114,30 x 60,30	2,30	2,00	320,00	60,65
100 x 65	114,30 x 76,10	2,30	2,00	320,00	62,15
100 x 80	114,30 x 88,90	2,30	2,30	320,00	62,15
100 x 100	114,30 x 114,30	2,30	2,30	320,00	63,15

Weitere Abmessungen auf Anfrage. Technische Änderungen vorbehalten.  
Je nach Abmessung können unterschiedliche Fertigungsverfahren angewandt werden.

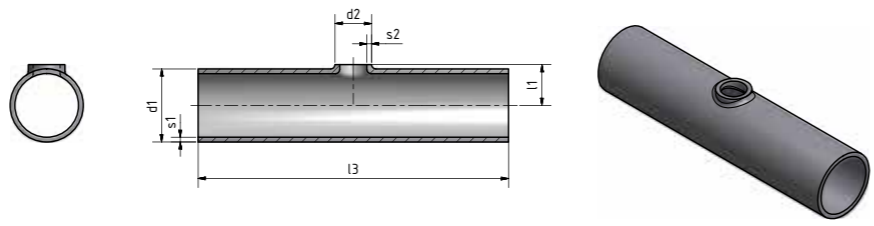

<b>ultron</b>	<b>finetron</b>	<b>TCC</b>	<b>safetron</b>	<b>weldtron</b>	<b>bpe-direct</b>
				•	
				•	
				•	
				•	
				•	
				•	
				•	
				•	
				•	
				•	
				•	
				•	
				•	
				•	
				•	
				•	
				•	
				•	
				•	
				•	
				•	
				•	
				•	

Further dimensions on request. Subject to alteration.  
 It depends on the dimensions, which manufacturing process will be used.

<b>Metric / DIN 11865</b>	<b>d1 x d2</b>	<b>s1</b>	<b>s2</b>	<b>l3</b>	<b>l1</b>
<b>DN / NW</b>	<b>mm</b>				
10 x 10	13,00 x 13,00	1,50	1,50	70,00	11,50
15 x 10	19,00 x 12,00	1,50	1,00	70,00	11,00
15 x 10	19,00 x 13,00	1,50	1,50	70,00	11,00
15 x 15	19,00 x 19,00	1,50	1,50	70,00	11,00
20 x 10	23,00 x 12,00	1,50	1,00	80,00	13,00
20 x 10	23,00 x 13,00	1,50	1,50	80,00	13,00
20 x 15	23,00 x 19,00	1,50	1,50	80,00	13,00
20 x 20	23,00 x 23,00	1,50	1,50	80,00	13,00
25 x 10	29,00 x 12,00	1,50	1,00	100,00	16,00
25 x 10	29,00 x 13,00	1,50	1,50	100,00	16,00
25 x 15	29,00 x 19,00	1,50	1,50	100,00	16,00
25 x 20	29,00 x 23,00	1,50	1,50	100,00	16,00
25 x 25	29,00 x 29,00	1,50	1,50	100,00	16,00
32 x 15	35,00 x 19,00	1,50	1,50	110,00	19,00
32 x 20	35,00 x 23,00	1,50	1,50	110,00	19,00
32 x 25	35,00 x 29,00	1,50	1,50	110,00	19,00
32 x 32	35,00 x 35,00	1,50	1,50	110,00	19,50
40 x 20	41,00 x 23,00	1,50	1,50	120,00	22,00
40 x 25	41,00 x 29,00	1,50	1,50	120,00	22,00
40 x 32	41,00 x 35,00	1,50	1,50	120,00	22,50
40 x 40	41,00 x 41,00	1,50	1,50	120,00	23,00

Weitere Abmessungen auf Anfrage. Technische Änderungen vorbehalten.  
 Je nach Abmessung können unterschiedliche Fertigungsverfahren angewandt werden.

<b>ultron</b>	<b>finetron</b>	<b>TCC</b>	<b>safetron</b>	<b>weldtron</b>	<b>bpe-direct</b>
				•	
				•	
				•	
				•	
				•	
				•	
				•	
				•	
				•	
				•	
				•	
				•	
				•	
				•	
				•	
				•	
				•	
				•	
				•	
				•	
				•	
				•	
				•	
				•	
				•	
				•	
				•	
				•	

Further dimensions on request. Subject to alteration.  
 It depends on the dimensions, which manufacturing process will be used.

<b>Metric / DIN 11865</b>	<b>d1 x d2</b>	<b>s1</b>	<b>s2</b>	<b>l3</b>	<b>l1</b>
<b>DN / NW</b>	<b>mm</b>				
50 x 25	53,00 x 29,00	1,50	1,50	160,00	28,00
50 x 32	53,00 x 35,00	1,50	1,50	160,00	28,50
50 x 40	53,00 x 41,00	1,50	1,50	160,00	29,00
50 x 50	53,00 x 53,00	1,50	1,50	160,00	30,00
65 x 32	70,00 x 35,00	2,00	1,50	210,00	37,00
65 x 40	70,00 x 41,00	2,00	1,50	210,00	37,50
65 x 50	70,00 x 53,00	2,00	1,50	210,00	38,50
65 x 65	70,00 x 70,00	2,00	2,00	210,00	40,00
80 x 40	85,00 x 41,00	2,00	1,50	260,00	45,00
80 x 50	85,00 x 53,00	2,00	1,50	260,00	46,00
80 x 65	85,00 x 70,00	2,00	2,00	260,00	47,50
80 x 80	85,00 x 85,00	2,00	2,00	260,00	47,50
100 x 65	104,00 x 70,00	2,00	2,00	310,00	57,00
100 x 80	104,00 x 85,00	2,00	2,00	310,00	57,00
100 x 100	104,00 x 104,00	2,00	2,00	310,00	58,00

Weitere Abmessungen auf Anfrage. Technische Änderungen vorbehalten.  
 Je nach Abmessung können unterschiedliche Fertigungsverfahren angewandt werden.





ultron	finetron	TCC	safetron	weldtron	bpe-direct
				x	
•	•	•		x	
				x	
•	•	•		x	
				x	
				x	
				x	
				x	
				x	
				x	
				x	
				x	
				x	
				x	
				x	
				x	
				x	
				x	
				x	
				x	
				x	
				x	
				x	
				x	
•	•	•		x	

x = Option „u“ acc. to DIN 11865 / Welds finished after welding on request  
Option „u“ gem. DIN 11865 / verschliffen auf Anfrage

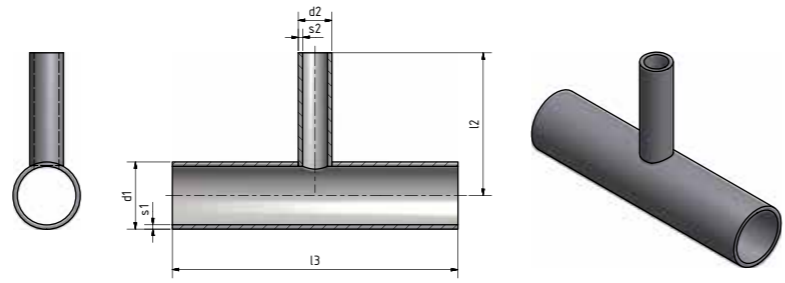

Metric / DIN 11865	d1 x d2	s1	s2	l3	l2
DN / NW	mm				
32 x 15	35,00 x 19,00	1,50	1,50	110,00	55,00
32 x 20	35,00 x 23,00	1,50	1,50	110,00	55,00
32 x 25	35,00 x 29,00	1,50	1,50	110,00	55,00
32 x 32	35,00 x 35,00	1,50	1,50	110,00	55,00
40 x 20	41,00 x 23,00	1,50	1,50	120,00	60,00
40 x 25	41,00 x 29,00	1,50	1,50	120,00	60,00
40 x 32	41,00 x 35,00	1,50	1,50	120,00	60,00
40 x 40	41,00 x 41,00	1,50	1,50	120,00	60,00
50 x 25	53,00 x 29,00	1,50	1,50	160,00	80,00
50 x 32	53,00 x 35,00	1,50	1,50	160,00	80,00
50 x 40	53,00 x 41,00	1,50	1,50	160,00	80,00
50 x 50	53,00 x 53,00	1,50	1,50	160,00	80,00
65 x 32	70,00 x 35,00	2,00	1,50	210,00	80,00
65 x 40	70,00 x 41,00	2,00	1,50	210,00	80,00
65 x 50	70,00 x 53,00	2,00	1,50	210,00	80,00
65 x 65	70,00 x 70,00	2,00	2,00	210,00	105,00
80 x 40	85,00 x 41,00	2,00	1,50	260,00	105,00
80 x 50	85,00 x 53,00	2,00	1,50	260,00	105,00
80 x 65	85,00 x 70,00	2,00	2,00	260,00	105,00
80 x 80	85,00 x 85,00	2,00	2,00	260,00	130,00
100 x 50	104,00 x 53,00	2,00	2,00	310,00	130,00
100 x 65	104,00 x 70,00	2,00	2,00	310,00	130,00
100 x 80	104,00 x 85,00	2,00	2,00	310,00	130,00
100 x 100	104,00 x 104,00	2,00	2,00	310,00	155,00
150 x 100	154,00 x 104,00	2,00	2,00	450,00	187,50
150 x 150	154,00 x 154,00	2,00	2,00	450,00	225,00

\* Wall thickness does not comply with DIN 11865  
\* Wandstärke entspricht nicht der DIN 11865

Further dimensions on request. Subject to alteration.  
It depends on the dimensions, which manufacturing process will be used.  
Weitere Abmessungen auf Anfrage. Technische Änderungen vorbehalten.  
Je nach Abmessung können unterschiedliche Fertigungsverfahren angewandt werden.



**45° T-PIECES**  
45° T-STÜCKE



**EXCENTRIC T-PIECES**  
EXZENTRISCHE T-STÜCKE



**THERMOWELLS**  
THERMOWELLS

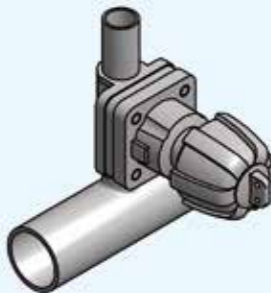

**T-PIECES WITH VALVE**  
T-STÜCKE MIT VENTIL



**Y-PIECES**  
Y-STÜCKE



**Y-PIECES WITH CLAMPS**  
Y-STÜCKE MIT STUTZEN



# REDUCERS REDUZIERUNGEN





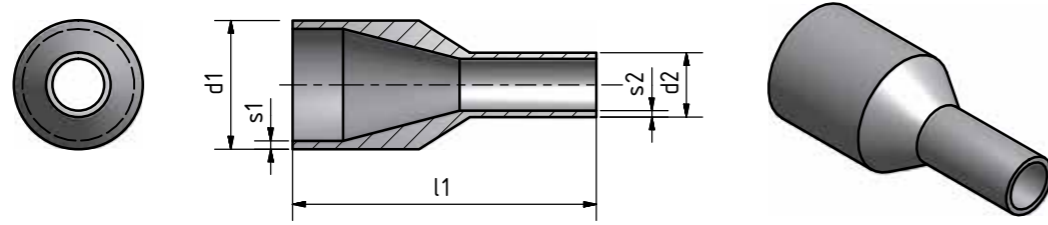

ultron	finetron	TCC	safetron	weldtron	bpe-direct
•	•	•		•	
•	•	•		•	
•	•	•		•	
•	•	•			
•	•	•			
				•	
•	•	•			
•	•	•			
				•	
•	•	•			
				•	
•	•	•			
				•	
•	•	•			
				•	
•	•	•			
				•	
•	•	•			
				•	

Metric / DIN 11865	d1	d2	s1	s2	l1
DN / NW	mm				
6 x 4	8,00 x 6,00		1,00	1,00	38,00
8 x 4	10,00 x 6,00		1,00	1,00	38,00
8 x 6	10,00 x 8,00		1,00	1,00	38,00
10 x 4	12,00 x 6,00		1,00	1,00	38,00
10 x 6	12,00 x 8,00		1,00	1,00	38,00
10 x 8	12,00 x 10,00		1,00	1,00	38,00
10 x 6	13,00 x 8,00		1,50	1,00	38,00
10 x 8	13,00 x 10,00		1,50	1,00	38,00
15 x 8	18,00 x 10,00		1,50	1,00	38,00
15 x 10	18,00 x 12,00		1,50	1,00	38,00
15 x 8	19,00 x 10,00		1,50	1,00	60,00
15 x 10	19,00 x 13,00		1,50	1,50	60,00
20 x 10	23,00 x 12,00		1,50	1,00	60,00
20 x 10	23,00 x 13,00		1,50	1,50	60,00
20 x 15	23,00 x 18,00		1,50	1,50	60,00
20 x 15	23,00 x 19,00		1,50	1,50	60,00
25 x 15	28,00 x 18,00		1,50	1,50	70,00
25 x 20	28,00 x 23,00		1,50	1,50	70,00
25 x 15	29,00 x 19,00		1,50	1,50	70,00
25 x 20	29,00 x 23,00		1,50	1,50	70,00
32 x 15	35,00 x 19,00		1,50	1,50	80,00
32 x 20	35,00 x 23,00		1,50	1,50	80,00
32 x 25	35,00 x 29,00		1,50	1,50	80,00

Further dimensions on request. Subject to alteration.  
Weitere Abmessungen auf Anfrage. Technische Änderungen vorbehalten.

ultron	finetron	TCC	safetron	weldtron	bpe-direct
				•	
				•	
				•	
				•	
				•	
				•	
				•	
				•	
				•	
				•	
				•	
				•	
				•	
				•	
				•	
				•	
				•	
				•	
				•	
				•	

Further dimensions on request. Subject to alteration.  
Weitere Abmessungen auf Anfrage. Technische Änderungen vorbehalten.

Metric / DIN 11865	d1	d2	s1	s2	l1
DN / NW	mm				
40 x 20	41,00 x 23,00		1,50	1,50	90,00
40 x 25	41,00 x 29,00		1,50	1,50	90,00
40 x 32	41,00 x 35,00		1,50	1,50	90,00
50 x 25	53,00 x 29,00		1,50	1,50	90,00
50 x 32	53,00 x 35,00		1,50	1,50	90,00
50 x 40	53,00 x 41,00		1,50	1,50	90,00
65 x 40	70,00 x 41,00		2,00	1,50	110,00
65 x 50	70,00 x 53,00		2,00	1,50	110,00
80 x 50	85,00 x 53,00		2,00	1,50	110,00
80 x 65	85,00 x 70,00		2,00	2,00	110,00
100 x 65	104,00 x 70,00		2,00	2,00	135,00
100 x 80	104,00 x 85,00		2,00	2,00	135,00
150 x 80	154,00 x 85,00		2,00	2,00	170,00
150 x 100	154,00 x 104,00		2,00	2,00	170,00

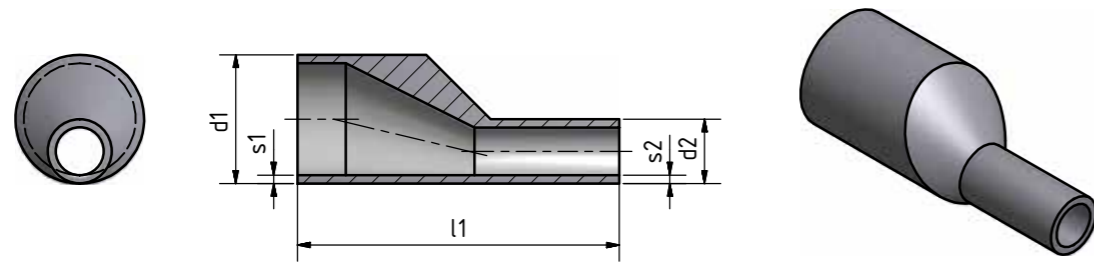

ultron	finetron	TCC	safetron	weldtron	bpe-direct
			•	•	•
			•	•	•
•	•	•	•	•	•
			•	•	•
			•	•	•
•	•	•	•	•	•
•	•	•	•	•	•
•	•	•	•	•	•
•	•	•	•	•	•
•	•	•	•	•	•
•	•	•	•	•	•
•	•	•	•	•	•
•	•	•	•	•	•
•	•	•	•	•	•
•	•	•	•	•	•
•	•	•	•	•	•
•	•	•	•	•	•
•	•	•	•	•	•
•	•	•	•	•	•
•	•	•	•	•	•

Imperial / DIN 11865	d1	d2	s1	s2	l1
Inch / Zoll	mm				
1/2 x 1/4	12,70 x 6,35	1,65	0,89	47,63	
1/2 x 3/8	12,70 x 9,53	1,65	0,89	47,63	
3/4 x 3/8	19,05 x 9,53	1,65	0,89	50,80	
3/4 x 1/2	19,05 x 12,70	1,65	1,65	53,98	
1 x 1/2	25,40 x 12,70	1,65	1,65	63,50	
1 x 3/4	25,40 x 19,05	1,65	1,65	53,98	
1 1/2 x 1/2	38,10 x 12,70	1,65	1,65	80,00	
1 1/2 x 3/4	38,10 x 19,05	1,65	1,65	76,20	
1 1/2 x 1	38,10 x 25,40	1,65	1,65	63,50	
2 x 1	50,80 x 25,40	1,65	1,65	85,73	
2 x 1 1/2	50,80 x 38,10	1,65	1,65	63,50	
2 1/2 x 1	63,50 x 25,40	1,65	1,65	100,00	
2 1/2 x 1 1/2	63,50 x 38,10	1,65	1,65	85,73	
2 1/2 x 2	63,50 x 50,80	1,65	1,65	63,50	
3 x 1 1/2	76,20 x 38,10	1,65	1,65	107,95	
3 x 2	76,20 x 50,80	1,65	1,65	85,73	
3 x 2 1/2	76,20 x 63,50	1,65	1,65	66,68	
4 x 2	101,60 x 50,80	2,11	1,65	130,18	
4 x 2 1/2	101,60 x 63,50	2,11	1,65	107,95	
4 x 3	101,60 x 76,20	2,11	1,65	98,43	
6 x 3	152,40 x 76,20	2,77	1,65	184,15	
6 x 4	152,40 x 101,60	2,77	2,11	142,88	

Further dimensions on request. Subject to alteration.  
Weitere Abmessungen auf Anfrage. Technische Änderungen vorbehalten.

ultron	finetron	TCC	safetron	weldtron	bpe-direct
			•	•	
			•	•	
			•	•	
			•	•	
			•	•	
			•	•	
			•	•	
			•	•	
			•	•	
			•	•	
			•	•	
			•	•	
			•	•	
			•	•	
			•	•	
			•	•	
			•	•	
			•	•	
			•	•	
			•	•	
			•	•	
			•	•	

Further dimensions on request. Subject to alteration.  
Weitere Abmessungen auf Anfrage. Technische Änderungen vorbehalten.

ISO / DIN 11865	d1	d2	s1	s2	l1
DN / NW	mm				
10 x 8	17,20 x 13,50	1,60	1,60	60,00	
15 x 8	21,30 x 13,50	1,60	1,60	60,00	
15 x 10	21,30 x 17,20	1,60	1,60	60,00	
20 x 8	26,90 x 13,50	1,60	1,60	60,00	
20 x 10	26,90 x 17,20	1,60	1,60	60,00	
20 x 15	26,90 x 21,30	1,60	1,60	60,00	
25 x 15	33,70 x 21,30	2,00	1,60	70,00	
25 x 20	33,70 x 26,90	2,00	1,60	70,00	
32 x 15	42,40 x 21,30	2,00	1,60	80,00	
32 x 20	42,40 x 26,90	2,00	1,60	80,00	
32 x 25	42,40 x 33,70	2,00	2,00	80,00	
40 x 15	48,30 x 21,30	2,00	1,60	90,00	
40 x 20	48,30 x 26,90	2,00	1,60	90,00	
40 x 25	48,30 x 33,70	2,00	2,00	90,00	
40 x 32	48,30 x 42,40	2,00	2,00	90,00	
50 x 20	60,30 x 26,90	2,00	1,60	100,00	
50 x 25	60,30 x 33,70	2,00	2,00	100,00	
50 x 32	60,30 x 42,40	2,00	2,00	100,00	
50 x 40	60,30 x 48,30	2,00	2,00	100,00	
65 x 25	76,10 x 33,70	2,00	2,00	110,00	
65 x 40	76,10 x 48,30	2,00	2,00	110,00	
65 x 50	76,10 x 60,30	2,00	2,00	110,00	
80 x 50	88,90 x 60,30	2,30	2,00	110,00	
80 x 65	88,90 x 76,10	2,30	2,00	110,00	
100 x 65	114,30 x 76,10	2,30	2,00	135,00	
100 x 80	114,30 x 88,90	2,30	2,30	135,00	
150 x 100	168,30 x 114,30	2,60	2,30	170,00	

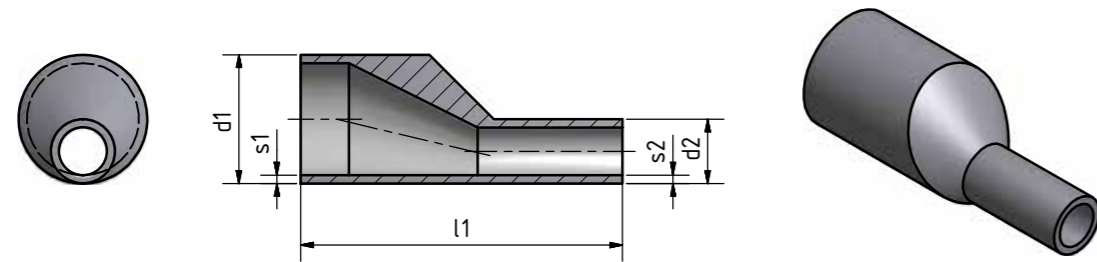

ultron	finetron	TCC	safetron	weldtron	bpe-direct
				•	
				•	
				•	
				•	
				•	
				•	
				•	
				•	
				•	
				•	
				•	
				•	
				•	
				•	
				•	
				•	
				•	
				•	
				•	
				•	
				•	
				•	
				•	
				•	
				•	
				•	
				•	

Metric / DIN 11865	d1	d2	s1	s2	l1
DN / NW	mm				
8 x 6	10,00 x 8,00		1,00	1,00	38,00
10 x 6	13,00 x 8,00		1,50	1,00	38,00
10 x 8	13,00 x 10,00		1,50	1,00	38,00
15 x 8	19,00 x 10,00		1,50	1,00	60,00
15 x 10	19,00 x 13,00		1,50	1,50	60,00
20 x 10	23,00 x 13,00		1,50	1,50	60,00
20 x 15	23,00 x 19,00		1,50	1,50	60,00
25 x 15	29,00 x 19,00		1,50	1,50	70,00
25 x 20	29,00 x 23,00		1,50	1,50	70,00
32 x 15	35,00 x 19,00		1,50	1,50	80,00
32 x 20	35,00 x 23,00		1,50	1,50	80,00
32 x 25	35,00 x 29,00		1,50	1,50	80,00
40 x 20	41,00 x 23,00		1,50	1,50	90,00
40 x 25	41,00 x 29,00		1,50	1,50	90,00
40 x 32	41,00 x 35,00		1,50	1,50	90,00
50 x 25	53,00 x 29,00		1,50	1,50	90,00
50 x 32	53,00 x 35,00		1,50	1,50	90,00
50 x 40	53,00 x 41,00		1,50	1,50	90,00
65 x 40	70,00 x 41,00		2,00	1,50	110,00
65 x 50	70,00 x 53,00		2,00	1,50	110,00
80 x 50	85,00 x 53,00		2,00	1,50	110,00
80 x 65	85,00 x 70,00		2,00	2,00	110,00
100 x 65	104,00 x 70,00		2,00	2,00	135,00
100 x 80	104,00 x 85,00		2,00	2,00	135,00
150 x 80	154,00 x 85,00		2,00	2,00	170,00
150 x 100	154,00 x 104,00		2,00	2,00	170,00

Further dimensions on request. Subject to alteration.  
Weitere Abmessungen auf Anfrage. Technische Änderungen vorbehalten.

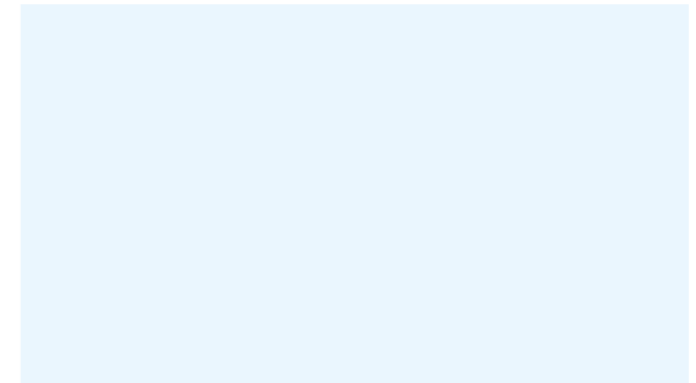
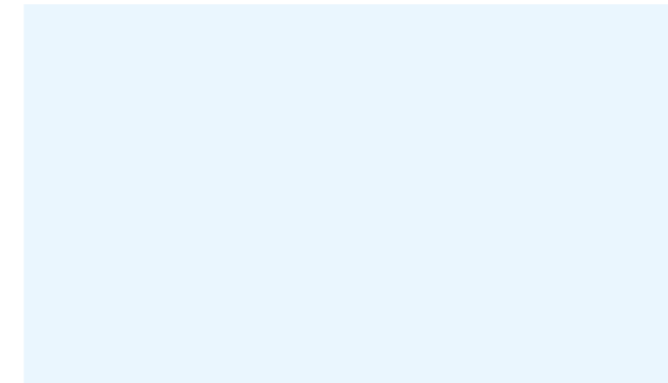
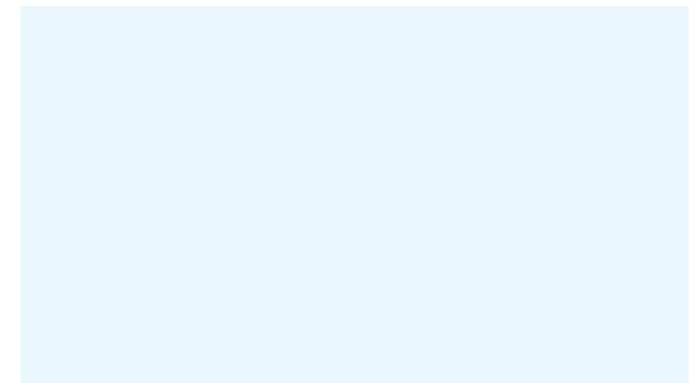
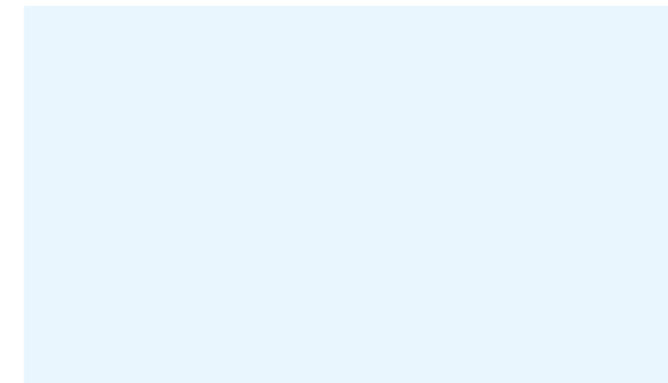
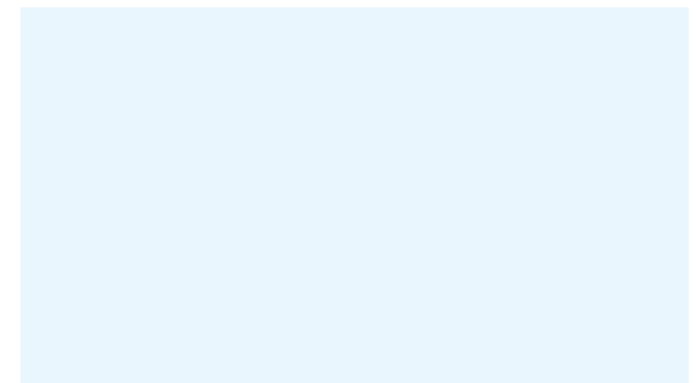
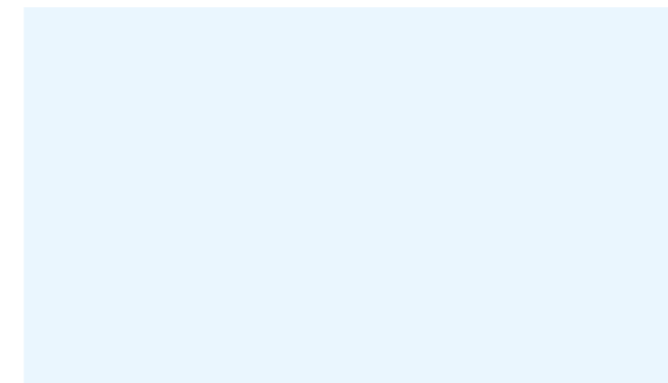

# ENDCAPS AND DOCKWEILER CAP

ENDKAPPEN UND  
DOCKWEILER CAP



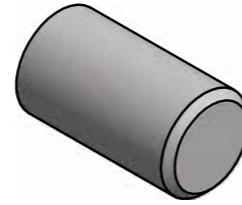
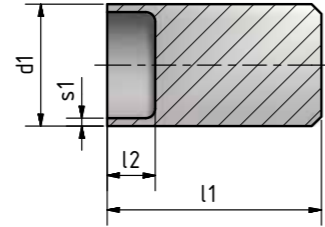

ultron	finetron	TCC	safetron	weldtron	bpe-direct
•	•	•			
•	•	•			
•	•	•			
•	•	•			
•	•	•			
•	•	•			
•	•	•			
•	•	•			
•	•	•			
•	•	•			
•	•	•			

ultron	finetron	TCC	safetron	weldtron	bpe-direct
•	•	•			
•	•	•			
•	•	•			
•	•	•			
•	•	•			
•	•	•			

Further dimensions on request. Subject to alteration.  
Weitere Abmessungen auf Anfrage. Technische Änderungen vorbehalten.

Imperial	d1	s1	l1	l2
Inch / Zoll	mm			
1/4	6,35	0,89	34,75	5,00
3/8	9,53	0,89	44,45	5,00
1/2	12,70	1,24 / 1,65	44,45	5,00
3/4	19,05	1,24 / 1,65	44,45	10,00
1	25,40	1,65	44,45	10,00
1 1/2	38,10	1,65	50,80	10,00
2	50,80	1,65	50,80	15,00
2 1/2	63,50	1,65	50,80	15,00
3	76,20	1,65	50,80	15,00
4	101,60	2,11	63,50	22,50
6	152,40	2,77	200,00*	150,00

Metric	d1	s1	l1	l2
DN / NW	mm			
10	12,00	1,00	37,00	5,00
15	18,00	1,50	37,00	10,00
20	23,00	1,50	45,00	10,00
25	28,00	1,50	45,00	10,00
32	35,00	1,50	45,00	10,00

\* Differing design: not machined but dished boiled end welded to tube stub.  
Abweichendes Design, nicht aus Vollmaterial gedreht, bestehend aus Klöpperboden und durch Schweißen verbundenes Rohrstück

INDUSTRIES

- Semiconductor industry
- Pharmaceutical industry
- Biotechnology
- Tank and apparatus engineering

INDUSTRIEN

- Halbleiterindustrie
- Pharmaindustrie
- Biotechnologie
- Behälter- und Apparatebau

FIELD OF APPLICATIONS

- For temporary capping of a line
- For leak testing filter housing, bubblers etc. with orbital weld connections
- On valves with weld connections
- During transportation of high purity equipment (Helium-Leak-Rate 1x10<sup>-9</sup> mbar l / s; 1x10<sup>-9</sup> scc / sec)

ANWENDUNGSBEREICHE

- Bei Arbeitsunterbrechungen
- Bei Dichtheitsprüfungen von Filtergehäusen, Bubbler u.a.
- Bei Arbeiten an Einschweißventilausgängen an Rohrleitungsenden
- Transport von hochreinem Equipment (Helium-Leck-Rate: 1x10<sup>-9</sup> mbar l / s; 1 x 10<sup>-9</sup> scc / sec)

BENEFITS

- More security**
  - Optimum weld quality – purge gas flow is guaranteed in contrast to conventional weld endcaps
  - Optimum preparation – the tube end is ready for orbital welding
  - No particle contamination caused by cutting and facing
- More flexibility**
  - Continuing a line is easy and without risk even in ultra pure production areas
  - The safe and contamination free solution for breaks during installation
- More economy**
  - Save time with easy and quick installation and deinstallation
  - Re usable cap and clamp

VORTEILE

- Mehr Sicherheit**
  - Optimale Verschweißbarkeit durch garantierten Spülgasfluss im Vergleich zu Schweißkappen
  - Ideale Rohrendenvorbereitung zum Orbitalschweißen
  - Keine Partikelverunreinigung durch späteres Trennen
- Mehr Flexibilität**
  - Spätere Erweiterung selbst in ultrareinen Produktionsbereichen
  - Keine Kontamination bei Unterbrechung der Montagearbeiten
- Mehr Wirtschaftlichkeit**
  - Zeitersparnis durch einfache und schnelle Montage
  - Verschlusshaube und Spannring wiederverwendbar

Application Anwendung	Dockweiler tube system Dockweiler Rohrsystem	Specifications Spezifikationen
UHP	<b>ultron</b>	<b>Material: UNS S31603 (316L)</b> Werkstoff: UNS S31603 (316L) <b>Standard surface: On request / Ra ≤ 0,25 µm / 10 µin</b> Oberfläche: auf Anfrage Ra Ra ≤ 0,25 µm / 10 µin <b>See ultron specification (page 12)</b> Siehe ultron Spezifikation (Seite 12)
CFOS	<b>TCC</b>	<b>Material UNS S31603 (316L)</b> Werkstoff: UNS S31603 (316L) <b>Standard surface / Standard Oberfläche: Ra ≤ 0,8 µm / 32 µin</b> Oberfläche: Standard: Ra ≤ Ra ≤ 0,8 µm / 32 µin <b>See TCC specification (page 18)</b> Siehe TCC Spezifikation (Seite 18)

Simple to install  
Einfache Installation

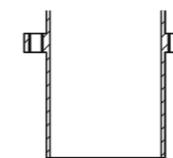

**Tube weld end**  
The tube weld end is welded to the tube and remains part of the installation

**Anschweissende**  
Das Anschweissende wird an das Rohr geschweißt und verbleibt in der Anlage

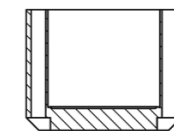

**The cap**  
with the gasket is put over the tube weld end and bolted into position

**Die Kappe**  
wird über das angeschweißte Rohrende gesetzt und verschraubt

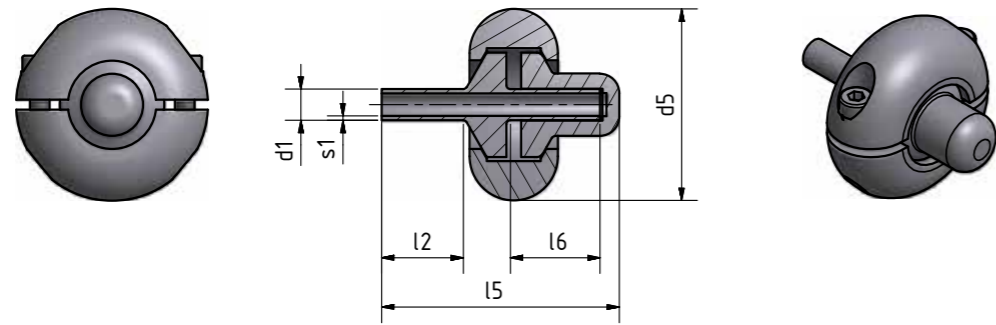

**TYPE A**

TCC	ultron	Imperial	DW Cap	d1	s1	l2	l5	d5	d6	l6	Pressure Druck	
		NW / Größe	Type	[mm]							[bar]	[psi]
•	•	1/4"	A	6,35	0,89	19,05	48,40	39,00	-	26,65	100	1500

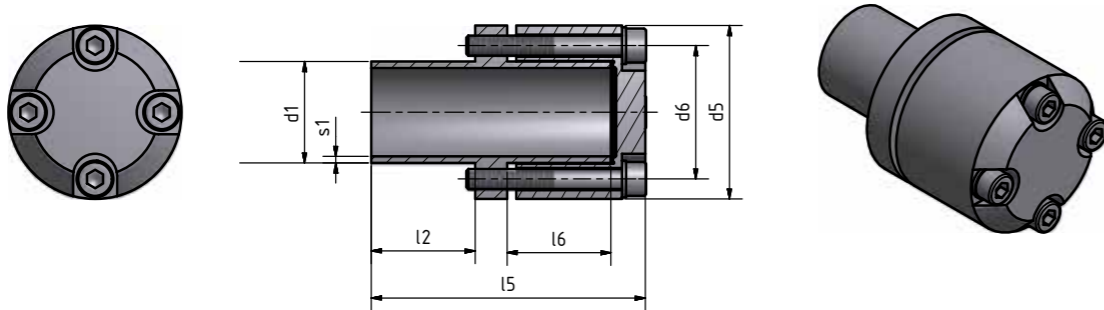

**TYPE B**

TCC	ultron	Imperial	DW Cap	d1	s1	l2	l5	d5	d6	l6	Pressure Druck	
		NW / Größe	Type	[mm]							[bar]	[psi]
•	•	1/2"	B	12,70	1,24	26,00	66,60	27,30	19,30	26,00	100	1500
•	•	1/2"	B	12,70	1,65	26,00	66,30	27,30	19,30	26,00	100	1500
•	•	3/4"	B	19,05	1,24	26,00	67,30	37,05	27,05	26,00	80	1200
•	•	3/4"	B	19,05	1,65	26,00	67,30	37,05	27,05	26,00	80	1200
•	•	1"	B	25,40	1,65	26,00	68,30	43,40	33,40	26,00	60	900
•	•	1 1/2"	B	38,10	1,65	30,00	77,30	57,90	46,90	30,00	60	900
•	•	2"	B	50,80	1,65	45,00	109,30	70,60	59,60	45,00	50	600
•	•	2 1/2"	B	63,50	1,65	45,00	110,30	83,30	72,30	45,00	50	600
•	•	3"	B	76,20	1,65	45,00	111,30	96,00	85,00	45,00	30	450
•	•	4"	B	101,60	2,11	55,00	132,30	121,40	110,40	55,00	20	300
•	•	6"	B	152,40	2,77	55,00	134,30	172,20	161,20	55,00	12	200

# CLAMPS, GASKETS AND CONNECTIONS

## KLAMMERN, DICHTUNGEN UND VERBINDUNGEN





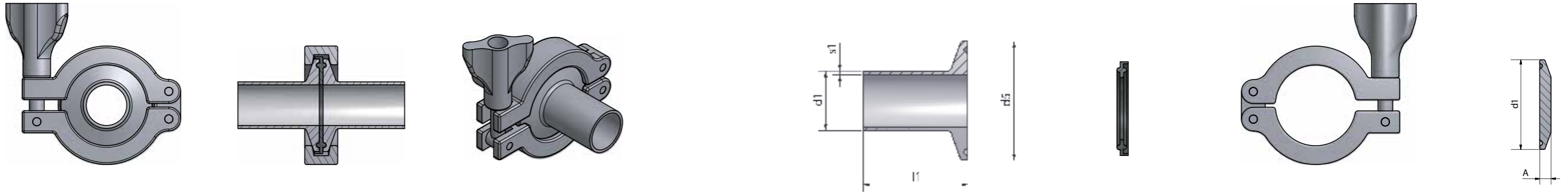

safetron ■	weldtron ■	bpe-direct ■	Metric		Connection complete Verbindung komplett		Ferrule Stutzen		Gasket Dichtung	Clamp Klammer	Cap Deckel				
			DIN 32676	DIN 11866	min.	max.	d1	s1	d5	l1 (A)	l1 (B)	Size / Größe	Size / Größe	d1	A
			DN / NW	d x s [mm]	[mm]	[mm]	[mm]	[mm]	[mm]	[mm]	[mm]	[mm]	[mm]	[mm]	[mm]
•	•	•	6	8,00 x 1,00	25,4	57,2	8,00	1,00	25,00	28,60	12,70	8,00 x 25,00	1	25,00	4,75
•	•	•	8	10,00 x 1,00	25,4	57,2	10,00	1,00	25,00	28,60	12,70	10,00 x 25,00	1	25,00	4,75
•	•	•	10	13,00 x 1,50	37,7	58,9	13,00	1,50	34,00	28,60	18,00	13,00 x 34,00	0	34,00	6,35
•	•	•	15	19,00 x 1,50	37,7	58,9	19,00	1,50	34,00	28,60	18,00	19,00 x 34,00	0	34,00	6,35
•	•	•	20	23,00 x 1,50	37,7	58,9	23,00	1,50	34,00	28,60	18,00	23,00 x 34,00	0	34,00	6,35
•	•	•	25	29,00 x 1,50	44,7	73,7	29,00	1,50	50,50	36,00	21,50	29,00 x 50,50	2	50,50	6,35
•	•	•	32	35,00 x 1,50	44,7	73,7	35,00	1,50	50,50	36,00	21,50	35,00 x 50,50	2	50,50	6,35
•	•	•	40	41,00 x 1,50	44,7	73,7	41,00	1,50	50,50	36,00	21,50	41,00 x 50,50	2	50,50	6,35
•	•	•	50	53,00 x 1,50	44,7	73,7	53,00	1,50	64,00	36,00	21,50	53,00 x 64,00	3	64,00	6,35
•	•	•	65	70,00 x 2,00	57,7	97,7	70,00	2,00	91,00	48,00	28,00	70,00 x 91,00	5	91,00	6,35
•	•	•	80	85,00 x 2,00	57,7	97,7	85,00	2,00	106,00	48,00	28,00	85,00 x 106,00	6	106,00	6,35
•	•	•	100	104,00 x 2,00	57,7	97,7	104,00	2,00	119,00	48,00	28,00	104,00 x 119,00	7	119,00	8,00
•	•	•	150	154,00 x 2,00	57,7	133,7	154,00	2,00	183,00	66,00	28,00	154,00 x 183,00	10	183,00	14,00

safetron ■	weldtron ■	bpe-direct ■	ISO		Connection complete Verbindung komplett		Ferrule Stutzen		Gasket Dichtung	Clamp Klammer	Cap Deckel				
			DIN 32676	DIN 11866	min.	max.	d1	s1	d5	l1 (A)	l1 (B)	Size / Größe	Size / Größe	d1	A
			DN / NW	d x s [mm]	[mm]	[mm]	[mm]	[mm]	[mm]	[mm]	[mm]	[mm]	[mm]	[mm]	[mm]
•	•	•	8	13,50 x 1,60	25,4	57,2	13,50	1,60	25,00	28,60	12,70	13,50 x 25,00	1	25,00	4,75
•	•	•	10	17,20 x 1,60	25,4	57,2	17,20	1,60	25,00	28,60	12,70	17,20 x 25,00	1	25,00	4,75
•	•	•	15	21,30 x 1,60	44,7	73,7	21,30	1,60	50,50	36,00	21,50	21,30 x 50,50	2	50,50	6,35
•	•	•	20	26,90 x 1,60	44,7	73,7	26,90	1,60	50,50	36,00	21,50	26,90 x 50,50	2	50,50	6,35
•	•	•	25	33,70 x 2,00	44,7	73,7	33,70	2,00	50,50	36,00	21,50	33,70 x 50,50	2	50,50	6,35
•	•	•	32	42,40 x 2,00	44,7	73,7	42,40	2,00	64,00	36,00	21,50	42,40 x 64,00	3	64,00	6,35
•	•	•	40	48,30 x 2,00	44,7	73,7	48,30	2,00	64,00	36,00	21,50	48,30 x 64,00	3	64,00	6,35
•	•	•	50	60,30 x 2,00	57,7	73,7	60,30	2,00	77,50	36,00	28,00	60,30 x 77,50	4	77,50	6,35
•	•	•	65	76,10 x 2,00	57,7	97,7	76,10	2,00	91,00	48,00	28,00	76,10 x 91,00	5	91,00	6,35
•	•	•	80	88,90 x 2,30	57,7	97,7	88,90	2,30	106,00	48,00	28,00	88,90 x 106,00	6	106,00	6,35
•	•	•	100	114,30 x 2,30	57,7	97,7	114,30	2,30	130,00	48,00	28,00	114,30 x 130,00	8	130,00	8,00

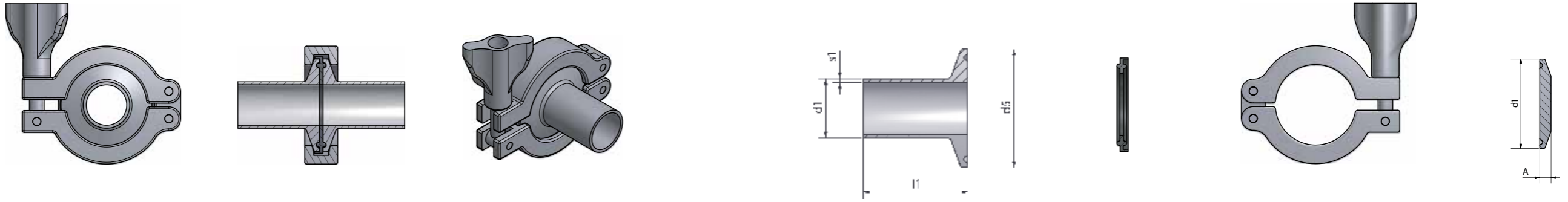

safetron ■	weldtron ■	bpe-direct ■	Imperial	Tube Rohr	Connection complete Verbindung komplett		Ferrule Stutzen			Gasket Dichtung	Clamp Klammer	Cap Deckel				
			DIN 32676 / ASME BPE	DIN 11866	min.	max.	d1	s1	d5	l1 (A)	l1 (B)	l1 (C)	Size / Größe	Size / Größe	d1	A
			Inch / Zoll	d x s [mm]	[mm]	[mm]	[mm]	[mm]	[mm]	[mm]	[mm]	[mm]	[mm]	[mm]	[mm]	[mm]
•	•	•	1/4	6,35 x 0,89	25,4	89,0	6,35	0,89	25,00	44,50*	28,58*	12,70*	6,35 x 25,00	1	25,00	4,75
•	•	•	3/8	9,53 x 0,89	25,4	89,0	9,53	0,89	25,00	44,50*	28,58*	12,70*	9,53 x 25,00	1	25,00	4,75
•	•	•	1/2	12,70 x 1,65	25,4	89,0	12,70	1,65	25,00	44,50*	28,58*	12,70*	12,70 x 25,00	1	25,00	4,75
•	•	•	3/4	19,05 x 1,65	27,1	90,7	19,05	1,65	25,00	44,50*	28,58*	12,70*	19,05 x 25,00	1	25,00	4,75
•	•	•	1	25,40 x 1,65	27,1	90,7	25,40	1,65	50,50	44,50*	28,58* / 36,00**	12,70* / 21,50**	25,40 x 50,50	2	50,50	6,35
•	•	•	1 1/2	38,10 x 1,65	27,1	90,7	38,10	1,65	50,50	44,50*	28,58* / 36,00**	12,70* / 21,50**	38,10 x 50,50	2	50,50	6,35
•	•	•	2	50,80 x 1,65	27,1	116,1	50,80	1,65	64,00	57,20*	28,58* / 36,00**	12,70* / 21,50**	50,80 x 64,00	3	64,00	6,35
•	•	•	2 1/2	63,50 x 1,65	27,1	116,1	63,50	1,65	77,50	57,20*	28,58* / 36,00**	12,70* / 28,00**	63,50 x 77,50	4	77,50	6,35
•	•	•	3	76,20 x 1,65	27,7	116,1	76,20	1,65	91,00	57,20*	28,58* / 48,00**	12,70* / 28,00**	76,20 x 91,00	5	91,00	6,35
•	•	•	4	101,60 x 2,11	33,5	154,1	101,60	2,11	119,00	57,20*	28,58* / 48,00**	12,70* / 28,00**	101,60 x 119,00	7	119,00	8,00
•	•	•	6	152,40 x 2,77	39,8	154,1	152,40	2,77	167,00	76,20*	38,10* / 66,00**	15,90* / 28,00**	152,40 x 167,00	9	167,00	14,00

\* Dimensions according to ASME BPE / Abmessungen gemäß ASME BPE  
 \*\* Dimensions according to DIN 32676 / Abmessungen gemäß DIN 32676



safetron ■	weldtron ■	bpe-direct ■	Imperial	Tank Ferrules Tankstutzen				Gasket Dichtung	Gasket Dichtung	Cap Deckel	
			DIN 32676 / ASME BPE	d1	s1	d5	l1 (A)	Size / Größe	Size / Größe	d1	A
			Inch / Zoll	[mm]	[mm]	[mm]	[mm]	[mm]	[mm]	[mm]	[mm]
•	•	•	1	29,50	3,90	50,50	41,30	29,50 x 50,50	2	50,50	6,35
•	•	•	1 1/2	42,60	4,10	50,50	41,30	42,60 x 50,50	2	50,50	6,35
•	•	•	2	55,70	4,30	63,90	44,50	55,70 x 63,90	3	64,00	6,35
•	•	•	2 1/2	68,80	4,50	77,40	44,50	68,80 x 77,40	4	77,50	6,35
•	•	•	3	81,90	4,70	90,90	46,00	81,90 x 90,90	5	91,00	6,35
•	•	•	4	108,10	5,70	119,00	54,00	108,10 x 119,00	7	119,00	8,00

**Standard Gaskets**

All standard sanitary gaskets according to DIN 32676 are moulded from FDA compliant compounds and fulfil USP class VI.

**Total traceability for the complete system**

Dockweiler gaskets are cleaned, dried and permanently marked. Mix-ups after removal from the packaging are eliminated.

**Lasermarking information:**

DOCKWEILER / DW-No.

**Standard Dichtungen**

Alle Standard-Dichtungen gemäß DIN 32676 werden aus FDA-konformen Werkstoffen gefertigt und erfüllen USP Class VI.

**Lückenlose Rückverfolgbarkeit für das komplette System**

Dockweiler Dichtungen sind dauerhaft markiert, gereinigt und getrocknet. Verwechslungen nach der Entnahme aus der Verpackung werden so ausgeschlossen.

**Informationen der Lasermarkierung:**

DOCKWEILER / DW-Nr.

**Materials**

**Werkstoffe**



Material / Werkstoff	PTFE	FKM	PTFE / FKM	EPDM	VMQ	PTFE / 316L	PTFE / EPDM
<b>Material acc. to ISO 1629 / ASTM D1418</b> Werkstoff gemäß ISO 1629 / ASTM D1418	<b>Polytetrafluoroethylene</b> Polytetrafluorethylen	<b>Perfluorinated rubber</b> Perfluorierter Kautschuk	<b>PTFE enveloped FKM</b> PTFE ummanteltes FKM	<b>Ethylene propylene diene rubber</b> Ethylen-Propylen-Dien-Kautschuk	<b>Platinum cured silicone rubber</b> Platin vernetztes Silikon-Kautschuk	<b>Composite of stainless steel 316L and PTFE /</b> Komposit aus Edelstahl 316L und PTFE	<b>PTFE enveloped EPDM</b> PTFE ummanteltes EPDM
<b>Trade name</b> Beispielhafter Handelsname	Teflon® Dyneon®	Viton® Fluorel®		Buna® Nordel®	Silopren® Silastic®		
<b>Diameter* Nennweite*</b>	Flange size ≤ 25 mm: Gasket without Lip, Flange size ≥ 34 mm: Gasket with Lip Flanschmaß ≤ 25 mm: Dichtung ohne Lippe, Flanschmaß ≥ 34 mm: Dichtung mit Lippe						
<b>*Not all diameters are available in all materials.</b> *Nicht alle Nennweiten in allen Werkstoffen verfügbar.	ISO 13,5 mm – 114,3 mm Metric 6,00 mm – 154,00 mm Imperial 1/4" – 6"						
<b>Temperature variations</b> Temperaturschwankungen	-	+	0	+	+	+	+
<b>Continuous steam</b> Konstanter Dampf	+	+	+	+	+	+	+
<b>Non-polar solvents</b> Unpolare Lösungsmittel	+	+	+	-	-	+	+
<b>Polar solvents</b> Polare Lösungsmittel	+	-	+	-	-	+	+
<b>Acid and active oxygen</b> Säure und aktiver Sauerstoff	+	+	+	+	+	+	+
<b>Acid / Säure</b>	+	+	+	+	+	+	+
<b>Alkaline / Basen</b>	+	+	+	+	-	+	+
<b>Hardness / Härte</b>	68 Shore A	82 Shore A	45 Shore A	45 Shore A	65 – 75 Shore A	80 Shore A	70 +/- 5 Shore A
<b>Density / Dichte</b>	3,45 g/cm <sup>3</sup>	1,28 g/cm <sup>3</sup>	1,9 g/cm <sup>3</sup>	2,1 g/cm <sup>3</sup>	1,2 g/cm <sup>3</sup>	1,85 g/cm <sup>3</sup>	1,25 g/cm <sup>3</sup>
<b>Compression set</b> Druckverformung	18,5 % 70 Hour / Std. 200 °C 392 °F	13 % 24 Hour / Std. 175 °C 347 °F	15 % 24 Hour / Std. 175 °C 347 °F	10 % 24 Hour / Std. 150 °C 302 °F	20 % 24 Hour / Std. 175 °C 347 °F	7 % 24 Hour / Std. 150 °C 302 °F	5 % 24 Hour / Std. 175 °C 347 °F
<b>Temperature range</b> Temperaturbereich	-15 to 230 °C 5 to 446 °F	-20 to 210 °C -4 to 410 °F	-60 to 180 °C -76 to 356 °F	-40 to 140 °C -40 to 284 °F	-60 to 200 °C -76 to 392 °F	-70 to 260 °C -94 to 500 °F	-70 to 180 °C -94 to 356 °F

+ = highly suitable / gut geeignet

0 = suitable / geeignet

- = not suitable / ungeeignet

The following gaskets are optional available beside the standard gaskets:

Neben den Standarddichtungen sind auch folgende Dichtungen optional erhältlich:



**Screen Gaskets**

Screen Gaskets provide prefiltration for critical membrane filters, coalescence of water vapour from process exhaust lines, particulate removal before fill and finish and more.

**Screen Gaskets**

Screen-Dichtungen schützen durch Vorfiltration empfindliche Systeme, wie z. B. Pumpen, Ventile, Spülköpfe und Abfülleinrichtungen vor Verunreinigungen.



**Smart Gasket**

The Smart Gasket valves are proven when validating sterility in high purity pharmaceutical systems.

**Smart Gasket**

Die Smart-Dichtungen erleichtern und beschleunigen den Validierungsprozess steriler Systeme. Sie ermöglichen auch den tottraumfreien Einbau von Thermoelementen.



**Controlled Compression Gaskets**

The Controlled Compression Gaskets cannot be overtightened but controls clamp compression to exactly the correct amount, allowing the properly positioned gasket to make a perfect surface I.D. seal with ferrules.

**Controlled Compression Gaskets**

Controlled-Compression-Dichtungen regulieren den Klemmdruck und sichern den ordnungsgemäßen Sitz der Dichtung.



**Orifice Plates**

Orifice Plates advance your system's performance, adjust flow rates, balance backflow and equalize back pressure during SIP procedures.

**Orifice Plates**

Orifice-Scheiben steigern die Leistungsfähigkeit Ihres Systems. So können zum Beispiel einzelne Anlagenteile auch ohne Blinddeckel abgesperrt, Durchflussraten justiert oder Gegendrucke ausgeglichen werden.

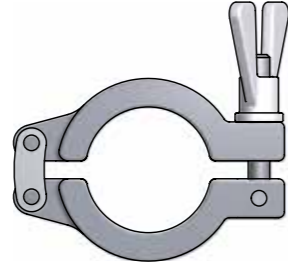
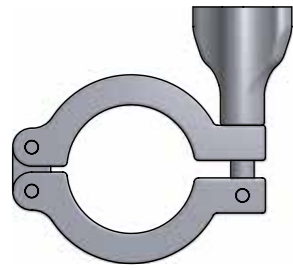

Size Größe	Flange diameter [mm] Flanschdurchmesser [mm]	Type of Nut Muttertype	Standard Clamp Standardklammer		Clamp acc. to ASME BPE Klammer gem. ASME BPE
			Max. allowable working pressure for complete connection Max. Betriebsdruck für die Klemmverbindung*	Knuckle Bolts Gelenkbolzen	Knuckle Bolts Gelenkbolzen
1	25,00	Wing nut / Flügelmutter	25 bar / 362 psig	2	1
0	34,00	Wing nut / Flügelmutter	25 bar / 362 psig	2	1
2	50,50	Wing nut / Flügelmutter	25 bar / 362 psig	2	1
3	64,00	Wing nut / Flügelmutter	25 bar / 362 psig	2	1
4	77,50	Wing nut / Flügelmutter	16 bar / 232 psig	2	1
5	91,00	Wing nut / Flügelmutter	16 bar / 232 psig	2	1
6	106,00	Wing nut / Flügelmutter	10 bar / 145 psig	2	1
7	119,00	Wing nut / Flügelmutter	10 bar / 145 psig	2	1
8	130,00	Wing nut / Flügelmutter	10 bar / 145 psig	2	1
9	167,00	Wing nut / Flügelmutter	10 bar / 145 psig	2	1
10	183,00	Wing nut / Flügelmutter	10 bar / 145 psig	2	1
	233,50	Wing nut / Flügelmutter	10 bar / 145 psig	2	1

\* acc. to DIN 32676 Standard / gem. DIN 32676

**3-SEGMENT-CLAMP**  
3-SEGMENTKLAMMER

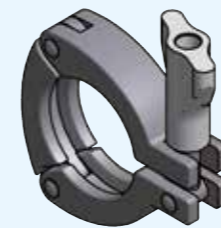

**SAFETY CLAMP**  
SICHERHEITSKLAMMER



**HIGH PRESSURE CLAMP**  
HOCHDRUCKKLAMMER

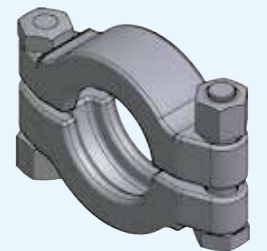

**CLAMP WITH HEXAGON**  
KLAMMER MIT SECHSKANTMUTTER

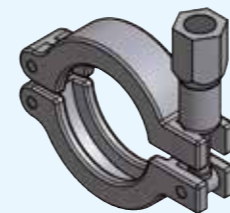



**LINE A**  
REIHE A

safetron weldtron bpe-direct	Metric	Tube Rohr	Screw connection complete Rohrverschraubung komplett	Threaded stub (male) Gewindestutzen			Weld stub (liner) Bundstutzen		Nut Nutmutter	O-ring O-Ring	Blind weld stub (liner) Blindbundstutzen	Blind threaded stub (male) Blindgewindestutzen			
	DN / NW	DIN 11866	l	d	d5	ls	c	ls	h	l4	d x s	d1	h	SW	c
		d x s [mm]	[mm]	[mm]		[mm]	[mm]	[mm]	[mm]	[mm]	[mm]	[mm]	[mm]		[mm]
•	•	10	13,00 x 1,50	76,0	38,0	28 x 1/8"	27,0	41,0							
•	•	15	19,00 x 1,50	76,0	44,0	34 x 1/8"	27,0	41,0							
•	•	20	23,00 x 1,50	76,0	54,0	44 x 1/6"	26,0	43,0							
•	•	25	29,00 x 1,50	77,0	63,0	52 x 1/6"	26,0	43,0							
•	•	32	35,00 x 1,50	88,0	70,0	58 x 1/6"	32,0	48,0							
•	•	40	41,00 x 1,50	88,0	78,0	65 x 1/6"	31,0	48,0							
•	•	50	53,00 x 1,50	89,0	92,0	78 x 1/6"	30,0	48,0							
•	•	65	70,00 x 2,00	113,0	112,0	95 x 1/6"	40,0	60,0							
•	•	80	85,00 x 2,00	117,0	127,0	110 x 1/4"	40,0	64,0							
•	•	100	104,00 x 2,00	120,0	148,0	130 x 1/4"	40,0	64,0							

**LINE B**  
REIHE B

safetron weldtron bpe-direct	ISO	Tube Rohr	Screw connection complete Rohrverschraubung komplett	Threaded stub (male) Gewindestutzen			Weld stub (liner) Bundstutzen		Nut Nutmutter	O-ring O-Ring	Blind weld stub (liner) Blindbundstutzen	Blind threaded stub (male) Blindgewindestutzen			
	DN / NW	DIN 11866	l	d	d5	ls	c	ls	h	l4	d x s	d1	h	SW	c
		d x s [mm]	[mm]	[mm]		[mm]	[mm]	[mm]	[mm]	[mm]	[mm]	[mm]	[mm]		[mm]
•	•	8	13,50 x 1,60	76,0	38,0	28 x 1/8"	27,0	41,0							
•	•	10	17,20 x 1,60	76,0	44,0	34 x 1/8"	27,0	41,0							
•	•	15	21,30 x 1,60	78,0	54,0	44 x 1/6"	27,0	43,0							
•	•	20	26,90 x 1,60	78,0	63,0	52 x 1/6"	27,0	43,0							
•	•	25	33,70 x 2,00	88,0	70,0	58 x 1/6"	32,0	48,0							
•	•	32	42,40 x 2,00	88,0	78,0	65 x 1/6"	32,0	48,0							
•	•	40	48,30 x 2,00	90,0	92,0	78 x 1/6"	31,0	49,0							
•	•	50	60,30 x 2,00	114,0	112,0	95 x 1/6"	40,0	60,0							
•	•	65	76,10 x 2,00	117,0	127,0	110 x 1/4"	40,0	64,0							
•	•	80	88,90 x 2,30	122,0	148,0	130 x 1/4"	40,0	64,0							



**LINE C**  
REIHE C

<b>safetron</b>	<b>weldtron</b>	<b>bpe-direct</b>
•	•	•
•	•	•
•	•	•
•	•	•
•	•	•
•	•	•
•	•	•

Imperial	Tube Rohr	Screw connection complete Rohrverschraubung komplett	Threaded stub (male) Gewindestutzen				Weld stub (liner) Bundstutzen		Nut Nutmutter	O-ring O-Ring	Blind weld stub (liner) Blindbundstutzen	Blind threaded stub (male) Blindgewindestutzen		
	DIN 11866	l	d	d5	ls	c	ls	h	l4	d x s	d1	h	SW	c
Inch / Zoll	d x s [mm]	[mm]	[mm]		[mm]	[mm]	[mm]	[mm]	[mm]	[mm]	[mm]	[mm]		[mm]
1/2"	12,70 x 1,65	76,0	38,0	28 x 1/8"	27,0	41,0	27,0	39,0	18,0	12,0 x 3,5	18,0	9,0	SW 19	24,0
3/4"	19,05 x 1,65	76,0	44,0	34 x 1/8"	27,0	41,0	27,0	39,0	18,0	18,0 x 3,5	24,0	9,0	SW 24	24,0
1"	25,40 x 1,65	77,0	63,0	52 x 1/6"	26,0	43,0	26,0	40,0	21,0	24,0 x 3,5	35,0	12,0	SW 41	24,0
1 1/2"	38,10 x 1,65	88,0	78,0	65 x 1/6"	30,0	49,0	30,0	46,5	21,0	37,0 x 5,0	48,0	13,0	SW 50	24,0
2"	50,80 x 1,65	89,0	92,0	78 x 1/6"	30,0	49,0	30,0	47,5	22,0	50,0 x 5,0	61,0	14,0	SW 65	24,0
2 1/2"	63,50 x 1,65	115,0	112,0	95 x 1/6"	40,0	60,0	40,0	63,0	25,0	62,0 x 5,0	79,0	16,0	SW 80	28,0
3"	76,20 x 1,65	117,0	127,0	110 x 1/4"	40,0	64,0	40,0	61,0	29,0	75,0 x 5,0	93,0	16,0	SW 95	28,0
4"	101,60 x 2,11	119,0	148,0	130 x 1/4"	40,0	64,0	40,0	65,0	31,0	100,0 x 5,0	114,0	20,0	SW 115	30,0

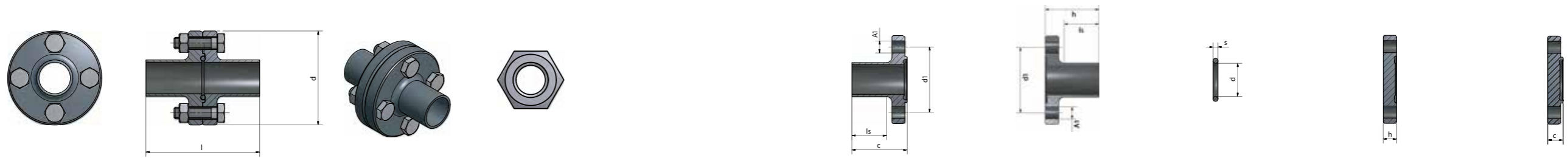

**LINE A**  
 REIHE A

safetron weldtron bpe-direct	Metric	Tube Rohr	Flanged connection complete Flanschverbindung komplett		Set of mounting bolts Satz Montageschrauben	Flange groove (male) Nutflansch			Flange collar (female) Bundflansch	Flange bore Flanschbohrung	O-ring O-Ring	Blind flange collar (female) Blindbundflansch	Blind flange groove (male) Blindnutflansch		
	DN / NW	DIN 11866	l	d	G	c	ls	d1	h	A1	d x s	h	c		
		d x s [mm]	[mm]	[mm]		[mm]	[mm]	[mm]	[mm]	[mm]	[mm]	[mm]	[mm]		
•	•	•	10	13,00 x 1,50	80,0	54,0	4/m8 x 30	41,5	26,0	37,0	40,0	4 x Ø 9,00	12,00 x 3,50	10,0	11,5
•	•	•	15	19,00 x 1,50	80,0	59,0	4/m8 x 30	41,5	26,0	42,0	40,0	4 x Ø 9,00	18,00 x 3,50	10,0	11,5
•	•	•	20	23,00 x 1,50	80,0	64,0	4/m8 x 30	41,5	26,0	47,0	40,0	4 x Ø 9,00	22,00 x 3,50	10,0	11,5
•	•	•	25	29,00 x 1,50	80,0	70,0	4/m8 x 30	41,5	26,0	53,0	40,0	4 x Ø 9,00	28,00 x 3,50	10,0	11,5
•	•	•	32	35,00 x 1,50	90,0	76,0	4/m8 x 30	46,5	31,0	59,0	45,0	4 x Ø 9,00	34,00 x 5,00	10,0	11,5
•	•	•	40	41,00 x 1,50	90,0	82,0	4/m8 x 30	46,5	31,0	65,0	45,0	4 x Ø 9,00	40,00 x 5,00	10,0	11,5
•	•	•	50	53,00 x 1,50	90,0	94,0	4/m8 x 30	46,5	31,0	77,0	45,0	4 x Ø 9,00	52,00 x 5,00	10,0	11,5
•	•	•	65	70,00 x 2,00	108,0	113,0	8/m8 x 30	55,5	42,0	95,0	54,0	8 x Ø 9,00	68,00 x 5,00	10,0	11,5
•	•	•	80	85,00 x 2,00	116,0	133,0	8/m10 x 35	59,5	42,0	112,0	58,0	8 x Ø 11,00	83,00 x 5,00	12,0	13,5
•	•	•	100	104,00 x 2,00	116,0	159,0	8/m10 x 40	59,5	42,0	137,0	58,0	8 x Ø 11,00	102,00 x 5,00	14,0	15,5

**LINE B**  
 REIHE B

safetron weldtron bpe-direct	ISO	Tube Rohr	Flanged connection complete Flanschverbindung komplett		Set of mounting bolts Satz Montageschrauben	Flange groove (male) Nutflansch			Flange collar (female) Bundflansch	Flange bore Flanschbohrung	O-ring O-Ring	Blind flange collar (female) Blindbundflansch	Blind flange groove (male) Blindnutflansch		
	DN / NW	DIN 11866	l	d	G	c	ls	d1	h	A1	d x s	h	c		
		d x s [mm]	[mm]	[mm]		[mm]	[mm]	[mm]	[mm]	[mm]	[mm]	[mm]	[mm]		
•	•	•	8	13,50 x 1,60	80,0	54,0	4/M8 x 30	41,5	26,0	37,0	40,0	4 x Ø 9,00	12,00 x 3,50	10,0	11,5
•	•	•	10	17,20 x 1,60	80,0	59,0	4/M8 x 30	41,5	26,0	42,0	40,0	4 x Ø 9,00	16,00 x 3,50	10,0	11,5
•	•	•	15	21,30 x 1,60	80,0	62,0	4/M8 x 30	41,5	26,0	45,0	40,0	4 x Ø 9,00	20,00 x 3,50	10,0	11,5
•	•	•	20	26,90 x 1,60	80,0	69,0	4/M8 x 30	41,5	26,0	52,0	40,0	4 x Ø 9,00	26,00 x 3,50	10,0	11,5
•	•	•	25	33,70 x 2,00	90,0	74,0	4/M8 x 30	46,5	31,0	57,0	45,0	4 x Ø 9,00	32,00 x 5,00	10,0	11,5
•	•	•	32	42,40 x 2,00	90,0	82,0	4/M8 x 30	46,5	31,0	65,0	45,0	4 x Ø 9,00	40,50 x 5,00	10,0	11,5
•	•	•	40	48,30 x 2,00	90,0	88,0	4/M8 x 30	46,5	31,0	71,0	45,0	4 x Ø 9,00	46,50 x 5,00	10,0	11,5
•	•	•	50	60,30 x 2,00	108,0	103,0	4/M8 x 30	55,5	42,0	85,0	54,0	4 x Ø 9,00	58,50 x 5,00	10,0	11,5
•	•	•	65	76,10 x 2,00	112,0	125,0	8/M10 x 30	57,5	42,0	104,0	56,0	8 x Ø 11,00	73,50 x 5,00	12,0	13,5
•	•	•	80	88,90 x 2,30	116,0	137,0	8/M10 x 35	59,5	42,0	116,0	58,0	8 x Ø 11,00	86,50 x 5,00	12,0	13,5
•	•	•	100	114,30 x 2,30	116,0	168,0	8/M10 x 35	59,5	42,0	146,0	58,0	8 x Ø 11,00	111,00 x 5,00	14,0	15,5

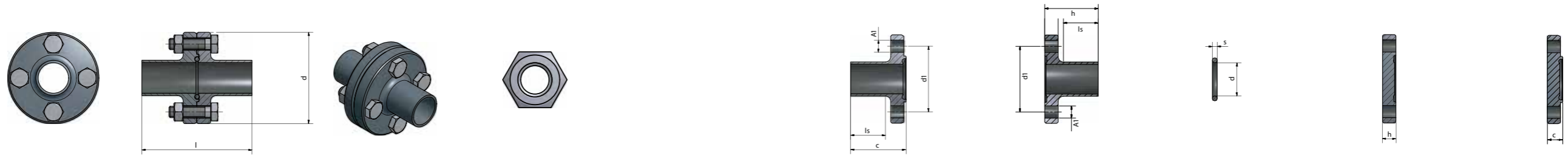

**LINE C**  
 REIHE C

safetron ■	weldtron ■	bpe-direct ■	Imperial	Tube Rohr	Flanged connection complete Flanschverbindung komplett	Set of mounting bolts Satz Montageschrauben	Flange groove (male) Nutflansch			Flange collar (female) Bundflansch	Flange bore Flanschbohrung	O-ring O-Ring	Blind flange collar (female) Blindbundflansch	Blind flange groove (male) Blindnutflansch	
			DIN 11866	l	d	G	c	ls	d1	h	A1	d x s	h	c	
			Inch / Zoll	d x s [mm]	[mm]	[mm]	[mm]	[mm]	[mm]	[mm]	[mm]	[mm]	[mm]	[mm]	[mm]
•	•	•	1/2"	12,70 x 1,65	80,0	54,0	4/M8 x 30	41,5	26,0	37,0	40,0	4 x Ø 9,00	12,00 x 3,50	10,0	11,5
•	•	•	3/4"	19,05 x 1,65	80,0	59,0	4/M8 x 30	41,5	26,0	42,0	40,0	4 x Ø 9,00	18,00 x 3,50	10,0	11,5
•	•	•	1"	25,40 x 1,65	80,0	66,0	4/M8 x 30	41,5	26,0	49,0	40,0	4 x Ø 9,00	24,00 x 3,50	10,0	11,5
•	•	•	1 1/2"	38,10 x 1,65	90,0	79,0	4/M8 x 30	46,5	31,0	62,0	45,0	4 x Ø 9,00	37,00 x 5,00	10,0	11,5
•	•	•	2"	50,80 x 1,65	90,0	92,0	4/M8 x 30	46,5	31,0	75,0	45,0	4 x Ø 9,00	50,00 x 5,00	10,0	11,5
•	•	•	2 1/2"	63,50 x 1,65	108,0	107,0	8/M8 x 30	55,5	42,0	89,0	54,0	8 x Ø 9,00	62,00 x 5,00	10,0	11,5
•	•	•	3"	76,20 x 1,65	112,0	125,0	8/M10 x 30	57,5	42,0	104,0	56,0	8 x Ø 11,00	75,00 x 5,00	12,0	13,5
•	•	•	4"	101,60 x 2,11	116,0	157,0	8/M10 x 35	59,5	42,0	135,0	58,0	8 x Ø 11,00	100,00 x 5,00	14,0	15,5





**LINE A**  
REIHE A

safetron	weldtron	bpe-direct
•	•	•
•	•	•
•	•	•
•	•	•
•	•	•
•	•	•
•	•	•
•	•	•
•	•	•
•	•	•

Metric	Tube Rohr	Clamp connection complete Klemmverbindung komplett	Clamp collar (female) Bundklemmstutzen	Clamp groove (male) Nutklemmstutzen	O-ring O-Ring	Clamp Klammer	Blind clamp collar (female) Blindbundklemmstutzen	Blind clamp groove (male) Blindnutklemmstutzen			
DN / NW	DIN 11866	l	d	ls	h	ls	c	d x s	Size / Größe	h*	h*
	d x s [mm]	[mm]	[mm]	[mm]	[mm]	[mm]	[mm]	[mm]	[mm]	[mm]	[mm]
10	13,00 x 1,50	76,0	34,0	26,0	38,0	26,0	39,5	12,00 x 3,50	0	11,5	13,0
15	19,00 x 1,50	76,0	34,0	26,0	38,0	26,0	39,5	18,00 x 3,50	0	11,5	13,0
20	23,00 x 1,50	76,0	50,5	26,0	38,0	26,0	39,5	22,00 x 3,50	2	11,5	13,0
25	29,00 x 1,50	77,0	50,5	28,0	38,5	28,0	40,0	28,00 x 3,50	2	11,5	13,0
32	35,00 x 1,50	88,0	50,5	30,0	44,0	30,0	45,5	34,00 x 5,00	2	11,5	13,0
40	41,00 x 1,50	88,0	64,0	30,0	44,0	30,0	45,5	40,00 x 5,00	3	11,5	13,0
50	53,00 x 1,50	89,0	77,5	30,0	44,5	30,0	46,0	52,00 x 5,00	4	13,5	15,0
65	70,00 x 2,00	113,0	91,0	40,0	56,5	40,0	58,0	68,00 x 5,00	5	13,5	15,0
80	85,00 x 2,00	117,0	106,0	40,0	58,5	40,0	60,0	83,00 x 5,00	6	13,5	15,0
100	104,00 x 2,00	120,0	130,0	40,0	60,0	40,0	61,5	102,00 x 5,00	8	13,5	15,0

\* Dimensions could differ / Abmaße können abweichen

**LINE B**  
REIHE B

safetron	weldtron	bpe-direct
•	•	•
•	•	•
•	•	•
•	•	•
•	•	•
•	•	•
•	•	•
•	•	•
•	•	•
•	•	•

ISO	Tube Rohr	Clamp connection complete Klemmverbindung komplett	Clamp collar (female) Bundklemmstutzen	Clamp groove (male) Nutklemmstutzen	O-ring O-Ring	Clamp Klammer	Blind clamp collar (female) Blindbundklemmstutzen	Blind clamp groove (male) Blindnutklemmstutzen			
DN / NW	DIN 11866	l	d	ls	h	ls	c	d x s	Size / Größe	h*	h*
	d x s [mm]	[mm]	[mm]	[mm]	[mm]	[mm]	[mm]	[mm]	[mm]	[mm]	[mm]
8	13,50 x 1,60	76,0	34,0	26,0	38,0	26,0	39,5	12,00 x 3,50	0	11,5	13,0
10	17,20 x 1,60	76,0	34,0	26,0	38,0	26,0	39,5	16,00 x 3,50	0	11,5	13,0
15	21,30 x 1,60	78,0	34,0	26,0	39,0	26,0	40,5	20,00 x 3,50	0	11,5	13,0
20	26,90 x 1,60	78,0	50,5	30,0	39,0	30,0	40,5	26,00 x 3,50	2	11,5	13,0
25	33,70 x 2,00	88,0	50,5	30,0	44,0	30,0	45,5	32,00 x 5,00	2	11,5	13,0
32	42,40 x 2,00	88,0	64,0	30,0	44,0	30,0	45,5	40,50 x 5,00	3	11,5	13,0
40	48,30 x 2,00	90,0	64,0	30,0	45,0	30,0	46,5	46,50 x 5,00	3	11,5	13,0
50	60,30 x 2,00	114,0	91,0	40,0	57,0	40,0	58,5	58,50 x 5,00	5	13,5	15,0
65	76,10 x 2,00	117,0	106,0	40,0	58,5	40,0	60,0	73,50 x 5,00	6	13,5	15,0
80	88,90 x 2,30	122,0	119,0	40,0	61,0	40,0	62,5	86,50 x 5,00	7	13,5	15,0

\* Dimensions could differ / Abmaße können abweichen

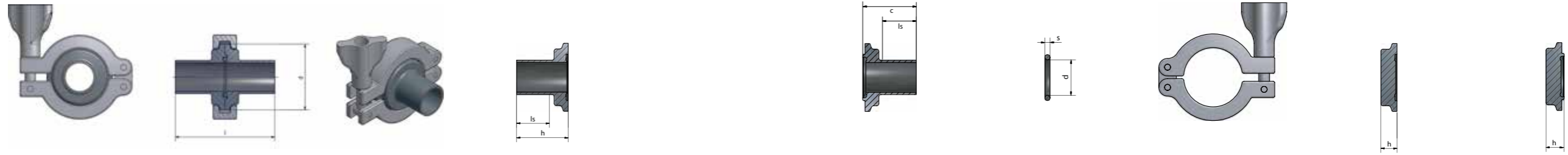

**LINE C**  
REIHE C

safetron	weldtron	bpe-direct
•	•	
•	•	
•	•	
•	•	
•	•	
•	•	
•	•	
•	•	

Imperial	Tube Rohr	Clamp connection complete Klemmverbindung komplett		Clamp collar (female) Bundklemmstutzen		Clamp groove (male) Nutklemmstutzen		O-ring O-Ring	Clamp Klammer	Blind clamp collar (female) Blindbundklemmstutzen	Blind clamp groove (male) Blindnutklemmstutzen
	DIN 11866	l	d	ls	h	ls	c	d x s	Size / Größe	h*	h*
Inch / Zoll	d x s [mm]	[mm]	[mm]	[mm]	[mm]	[mm]	[mm]	[mm]	[mm]	[mm]	[mm]
1/2"	12,70 x 1,65	76,0	34,0	26,0	38,0	26,0	39,5	12,00 x 3,50	0	11,5	13,0
3/4"	19,05 x 1,65	76,0	34,0	26,0	38,0	26,0	39,5	18,00 x 3,50	0	11,5	13,0
1"	25,40 x 1,65	77,0	50,5	28,0	38,5	28,0	40,0	24,00 x 3,50	2	11,5	13,0
1 1/2"	38,10 x 1,65	88,0	64,0	30,0	44,0	30,0	45,5	37,00 x 5,00	3	11,5	13,0
2"	50,80 x 1,65	89,0	77,5	30,0	44,5	30,0	46,0	50,00 x 5,00	4	13,5	15,0
2 1/2"	63,50 x 1,65	115,0	91,0	40,0	57,5	40,0	59,0	62,00 x 5,00	5	13,5	15,0
3"	76,20 x 1,65	117,0	106,0	40,0	58,5	40,0	60,0	75,00 x 5,00	6	13,5	15,0
4"	101,60 x 2,11	119,0	130,0	40,0	59,5	40,0	61,0	100,00 x 5,00	8	13,5	15,0

\* Dimensions could differ / Abmaße können abweichen

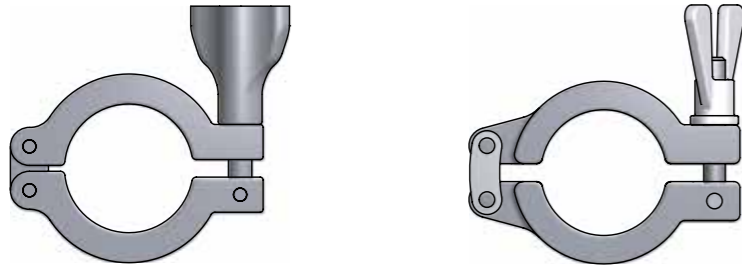

Size Größe	Flange diameter Flanschdurchmesser	Type of Nut Muttertype	Max. allowable working pressure for complete connetion* Max. Betriebsdruck für die Klemmverbindung*	Knuckle Bolts Gelenkbolzen
1	25,00 mm	Wing nut / Flügelmutter	40 bar / 580 psig	2
0	34,00 mm	Wing nut / Flügelmutter	40 bar / 580 psig	2
2	50,50 mm	Wing nut / Flügelmutter	40 bar / 580 psig	2
3	64,00 mm	Wing nut / Flügelmutter	40 bar / 580 psig	2
4	77,50 mm	Wing nut / Flügelmutter	25 bar / 362 psig	2
5	91,00 mm	Wing nut / Flügelmutter	25 bar / 362 psig	2
6	106,00 mm	Wing nut / Flügelmutter	16 bar / 232 psig	2
7	119,00 mm	Wing nut / Flügelmutter	16 bar / 232 psig	2
8	130,00 mm	Wing nut / Flügelmutter	16 bar / 232 psig	2
9	167,00 mm	Wing nut / Flügelmutter	16 bar / 232 psig	2
10	183,00 mm	Wing nut / Flügelmutter	16 bar / 232 psig	2
	233,50 mm	Wing nut / Flügelmutter	16 bar / 232 psig	2

\* acc. to / gem. DIN 11864-3 Standard

**3-SEGMENT-CLAMP**  
3-SEGMENTKLAMMER

**3-SEGMENT-CLAMP WITH HEXAGON**  
3-SEGMENTKLAMMER MIT SECHSKANTMUTTER

**HIGH PRESSURE CLAMP**  
HOCHDRUCKKLAMMER

**CLAMP WITH HEXAGON**  
KLAMMER MIT SECHSKANTMUTTER

**SAFETY CLAMP**  
SICHERHEITSKLAMMER

**Standard O-rings**  
All standard O-rings according to DIN 11864-1, -2, -3 are moulded from FDA compliant compounds and fulfil USP class VI.

**Standard O-Ringe**  
Alle Standard-O-Ringe gemäß DIN 11864-1, -2, -3 werden aus FDA-konformen Werkstoffen gefertigt und erfüllen USP Class VI.

Material acc. to ISO 1629 / ASTM D1418 Werkstoff gemäß ISO 1629 / ASTM D1418	PTFE enveloped FKM PTFE ummanteltes FKM	EPDM Ethylene Propylene Diene Rubber EPDM Eethylen-Propylen-Dien-Kautschuk
Trade name Beispielhafter Handelsname	-	Buna® Nordel®
Temperature variations Temperaturschwankungen	0	+
Continuous steam Konstanter Dampf	+	+
Non-polar solvents Unpolare Lösungsmittel	+	-
Polar solvents Polare Lösungsmittel	+	+
Acid and active oxygen Säure und aktiver Sauerstoff	+	+
Acid Säure	+	+
Alkaline Basen	+	+
Hardness Härte	45 Shore A	45 Shore A
Density Dichte	1,9 g/cm <sup>3</sup>	2,1 g/cm <sup>3</sup>
Compression set Druckverformung	15 % 24 Hour / Std.	10 % 24 Hour / Std.
Temperature range Temperaturbereich	-60 - 180 °C -76 - 356 °F	-40 - 140 °C -40 - 284 °F

+ = highly suitable / gut geeignet      0 = suitable / geeignet      - = not suitable / ungeeignet

**Diameters**  
Nennweiten

Metric		ISO		Imperial	
Tube / Rohr	O-ring / O-Ring	Tube / Rohr	O-ring / O-Ring	Tube / Rohr	O-ring / O-Ring
DN / NW	d x s [mm]	DN / NW	d x s [mm]	Inch / Zoll	d x s [mm]
10	12,00 x 3,50	8	12,00 x 3,50	1/2	12,00 x 3,50
15	18,00 x 3,50	10	16,00 x 3,50	3/4	18,00 x 3,50
20	22,00 x 3,50	15	20,00 x 3,50	1	24,00 x 3,50
25	28,00 x 3,50	20	26,00 x 3,50	1 1/2	37,00 x 5,00
32	34,00 x 5,00	25	32,00 x 5,00	2	50,00 x 5,00
40	40,00 x 5,00	32	40,50 x 5,00	2 1/2	62,00 x 5,00
50	52,00 x 5,00	40	46,50 x 5,00	3	75,00 x 5,00
65	68,00 x 5,00	50	58,50 x 5,00	4	100,00 x 5,00
80	83,00 x 5,00	65	73,50 x 5,00		
100	102,00 x 5,00	80	86,50 x 5,00		

Complete Kit  
Komplette Verbindung

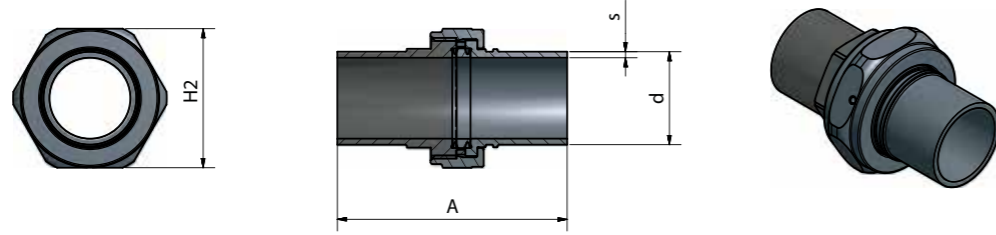

			Dimensions Abmessungen								Pressure Druck				
			Imperial	d	s	A	L	H1	H2						
			System	Inch	Material	[mm]	[mm]	[mm]	[mm]	[mm]	[Inch]	[mm]	[Inch]	[bar]	[psi]
•	•	•	201	1/4	316L	6,35	0,89	62,8	19	11	7/16	19	3/4	424	6149
•	•	•	402	3/8	316L	9,53	0,89	62,8	19	16	5/8	27	1 1/16	271	3930
•	•	•	603	1/2	316L	12,7	1,24	62,8	19	16	5/8	27	1 1/16	287	4162
•	•	•	503	1/2	316L	12,7	1,65	62,8	19	16	5/8	27	1 1/16	368	5337
•	•	•	1004	3/4	316L	19,05	1,24	62,8	19	22	7/8	32	1 1/4	186	2698
•	•	•	904	3/4	316L	19,05	1,65	62,8	19	22	7/8	32	1 1/4	251	3640
•	•	•	1305	1	316L	25,4	1,65	62,8	19	27	1 1/16	38	1 1/2	185	2683

			Dimensions Abmessungen								Pressure Druck				
			ISO	d	s	A	L	H1	H2						
			System	DN/NW	Material	[mm]	[mm]	[mm]	[mm]	[mm]	[Inch]	[mm]	[Inch]	[bar]	[psi]
•	•	•	603	8	316L	13,5	1,6	62,8	19	16	5/8	27	1 1/16	344	4989
•	•	•	704	10	316L	17,2	1,6	62,8	19	22	7/8	32	1 1/4	264	3829
•	•	•	1105	15	316L	21,3	1,6	62,8	19	27	1 1/16	38	1 1/2	209	3031

			Dimensions Abmessungen								Pressure Druck				
			Metric	d	s	A	L	H1	H2						
			System	DN/NW	Material	[mm]	[mm]	[mm]	[mm]	[mm]	[Inch]	[mm]	[Inch]	[bar]	[psi]
•	•	•	101	4	316L	6	1	62,8	19	11	7/16	19	3/4	452	6555
•	•	•	302	6	316L	8	1	62,8	19	16	5/8	27	1 1/16	328	4757
•	•	•	402	8	316L	10	1	62,8	19	16	5/8	27	1 1/16	258	3742
•	•	•	603	10	316L	12	1	62,8	19	16	5/8	27	1 1/16	212	3075
•	•	•	603	10	316L	13	1,5	62,8	19	16	5/8	27	1 1/16	330	4786
•	•	•	804	15	316L	18	1,5	62,8	19	22	7/8	32	1 1/4	232	3365
•	•	•	904	15	316L	19	1,5	62,8	19	22	7/8	32	1 1/4	219	3176
•	•	•	1205	20	316L	23	1,5	62,8	19	27	1 1/16	38	1 1/2	178	2582

**Disassembly tool**  
One disassembly tool for all systems sizes

**Demontagewerkzeug**  
Ein Demontagewerkzeug für alle Systemgrößen

Parts  
Einzelteile



			Dimensions Abmessungen									
			Imperial	Screw joint				Pressure Joint				
			System	Inch	Material	d	s	L	A	H1	A	
			System	Inch	Material	[mm]	[mm]	[mm]	[mm]	[mm]	[Inch]	[mm]
•	•	•	201	1/4	316L	6,35	0,89	19	35,0	11	7/16	30,0
•	•	•	402	3/8	316L	9,53	0,89	19	35,0	16	5/8	30,0
•	•	•	603	1/2	316L	12,7	1,24	19	35,0	16	5/8	30,0
•	•	•	503	1/2	316L	12,7	1,65	19	35,0	16	5/8	30,0
•	•	•	1004	3/4	316L	19,05	1,24	19	35,0	22	7/8	30,0
•	•	•	904	3/4	316L	19,05	1,65	19	35,0	22	7/8	30,0
•	•	•	1305	1	316L	25,4	1,65	19	35,0	27	1 1/16	30,0

			Dimensions Abmessungen									
			ISO	Screw joint				Pressure Joint				
			System	DN/NW	Material	d	s	L	A	H1	A	
			System	DN/NW	Material	[mm]	[mm]	[mm]	[mm]	[mm]	[Inch]	[mm]
•	•	•	603	8	316L	13,5	1,6	19	35,0	16	5/8	30,0
•	•	•	704	10	316L	17,2	1,6	19	35,0	22	7/8	30,0
•	•	•	1105	15	316L	21,3	1,6	19	35,0	27	1 1/16	30,0

			Dimensions Abmessungen									
			Metric	Screw joint				Pressure Joint				
			System	DN/NW	Material	d	s	L	A	H1	A	
			System	DN/NW	Material	[mm]	[mm]	[mm]	[mm]	[mm]	[Inch]	[mm]
•	•	•	101	4	316L	6	1	19	35,0	11	7/16	30,0
•	•	•	302	6	316L	8	1	19	35,0	16	5/8	30,0
•	•	•	402	8	316L	10	1	19	35,0	16	5/8	30,0
•	•	•	603	10	316L	12	1	19	35,0	16	5/8	30,0
•	•	•	603	10	316L	13	1,5	19	35,0	16	5/8	30,0
•	•	•	804	15	316L	18	1,5	19	35,0	22	7/8	30,0
•	•	•	904	15	316L	19	1,5	19	35,0	22	7/8	30,0
•	•	•	1205	20	316L	23	1,5	19	35,0	27	1 1/16	30,0

**Information**  
about **Endcaps**, **Seals** and **Nuts** can be found on page 88.

**Informationen**  
zu **Endkappen**, **Dichtungen** und **Muttern** finden Sie auf Seite 88.

Endcaps, Nuts and Seals  
Endkappen, Muttern und Dichtungen

Endcap / Endkappe

System	H [mm]	Material	
1	11,00	316L	1.4435
2	16,00	316L	1.4435
3	16,00	316L	1.4435
4	22,00	316L	1.4435
5	27,00	316L	1.4435

Nut / Mutter

System	Imperial	Metric	ISO	Material	
1	6,35	6,00		316L	1.4435
2	9,53	8,00 10,00	10,00	316L	1.4435
3	12,70	12,00 13,00	13,00	316L	1.4435
4	19,05	18,00 19,00	19,00	316L	1.4435
5	25,40	23,00	23,00	316L	1.4435

Seal / Dichtung

System	Tube Dimension / Rohrabmessungen	d [mm]	Material	
20	Imperial 6,35 x 0,89	8,95	316L	1.4435
40	Imperial 9,53 x 0,89	12,35	316L	1.4435
60	Imperial 12,7 x 1,24	15,25	316L	1.4435
50	Imperial 12,7 x 1,65	15,25	316L	1.4435
100	Imperial 19,05 x 1,24	21,60	316L	1.4435
90	Imperial 19,05 x 1,65	21,60	316L	1.4435
130	Imperial 25,4 x 1,65	27,20	316L	1.4435
60	ISO 13,5 x 1,6	15,25	316L	1.4435
70	ISO 17,2 x 1,6	21,60	316L	1.4435
110	ISO 21,3 x 1,6	27,20	316L	1.4435
10	Metric 6 x 1	8,95	316L	1.4435
30	Metric 8 x 1	12,35	316L	1.4435
40	Metric 10 x 1	12,35	316L	1.4435
60	Metric 12 x 1	15,25	316L	1.4435
60	Metric 13 x 1,5	15,25	316L	1.4435
80	Metric 18 x 1,5	21,60	316L	1.4435
90	Metric 19 x 1,5	21,60	316L	1.4435
120	Metric 23 x 1,5	27,20	316L	1.4435

**COAX**  
**COAX**



## COAX – the coaxial tube system

For the safe transport of explosive, toxic, corrosive or highly viscous media, we offer a safe solution in the form of the COAX twin wall tube system. COAX tubes and fittings consist of an inner process tube and an outer safety tube, between which, for example, a carrier gas reports leaks to a control room or steam keeps viscous media liquid in the process tube. Both tubes are prepared for orbital welding and made of AISI 316L or 304L stainless steel. Simple upgrades, even in existing plants and equipment, are possible at any time.

Spacers center the process tube and ensure a safe flow between the inner and outer tube. In the event of a leak in the process tubes, the escaping medium flows into the safety space where it can be rendered harmless and discharged.

## COAX – das Doppelwandrohr-System

Für den sicheren Transport von explosiven, toxischen, korrosiven oder hochviskosen Medien bieten wir mit dem Doppelwandrohr-System COAX eine sichere Lösung an. COAX-Rohre und -Formteile bestehen aus einem inneren Prozess- und einem äußeren Sicherheitsrohr, zwischen denen z. B. ein Trägergas Leckagen an eine Leitwarte meldet oder Dampf viskose Medien im Prozessrohr flüssig hält. Beide Rohre sind zum Orbitalschweißen vorbereitet und aus Edelstahl AISI 316L oder 304L hergestellt. Eine einfache Nachrüstung auch in bereits bestehende Anlagen und Einrichtungen ist jederzeit möglich.

Abstandshalter zentrieren das Prozessrohr und gewährleisten einen sicheren Durchfluss zwischen dem inneren und dem äußeren Rohr. Bei einer auftretenden Undichtigkeit im Prozessrohr strömt das austretende Medium in den Sicherheitsraum und kann hier unschädlich gemacht und abgeleitet werden.

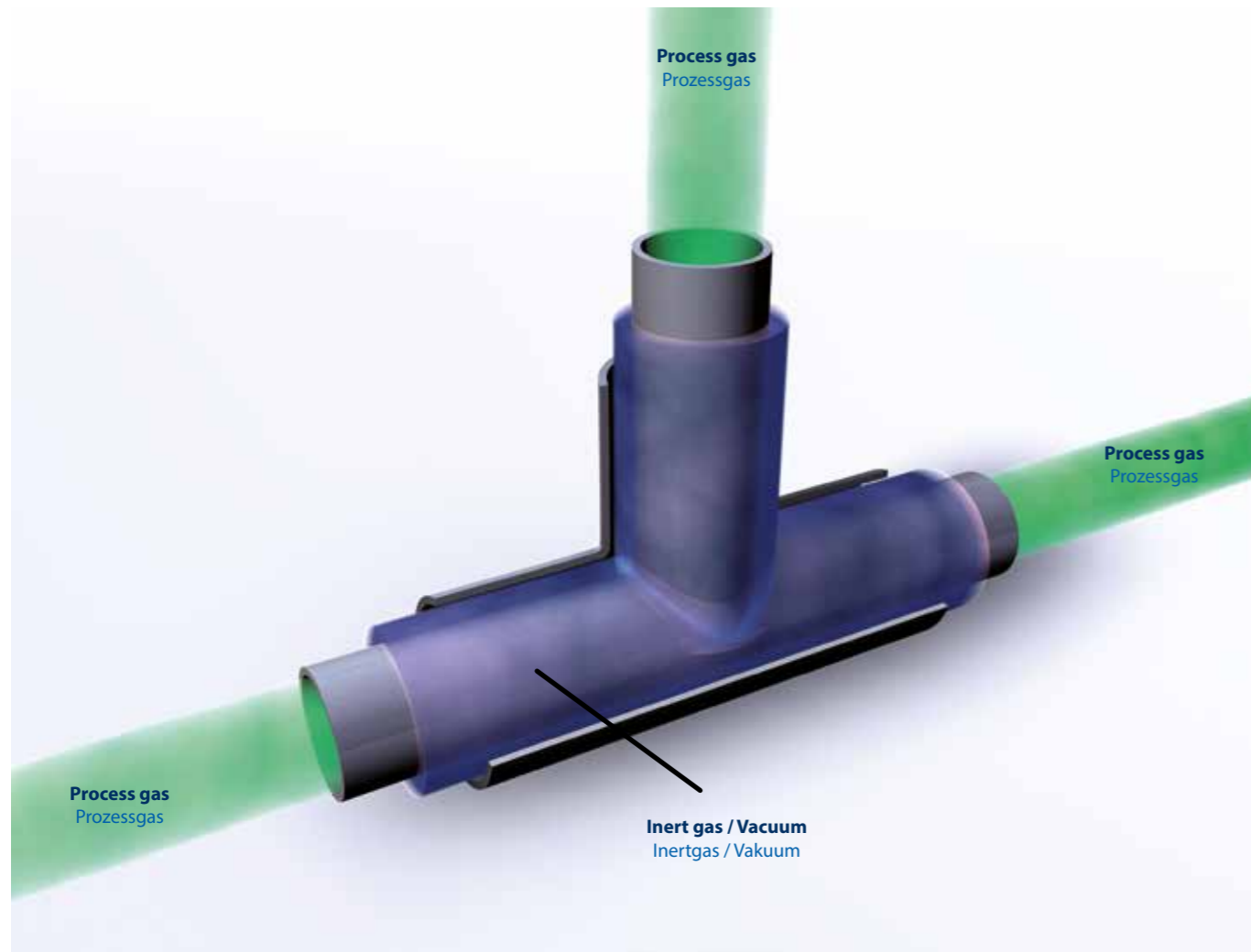

## Tube to tube or tube to fitting

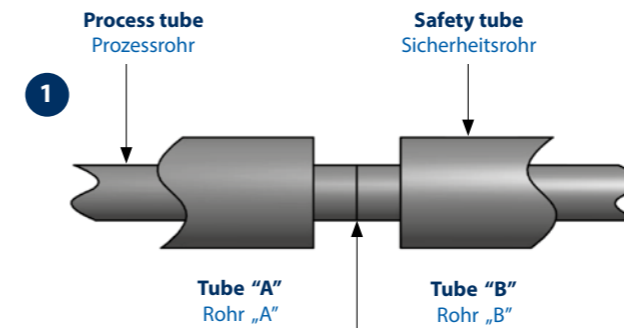

**Orbital weld the process tube and helium leak test**  
Orbitalschweißung des Prozessrohres, mit anschließendem Helium-Leck-Test

## Rohr an Rohr oder Rohr an Formteil

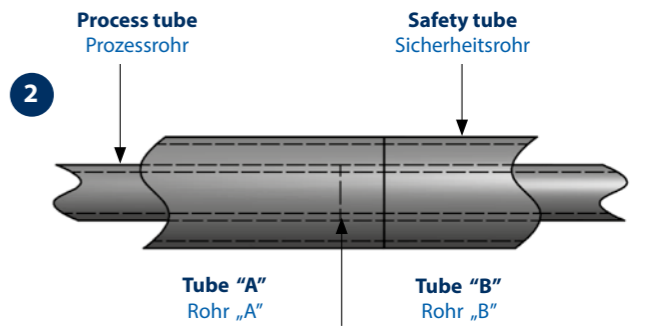

- Slide the safety tubes together so that the weld on the inner process tube is covered
- Orbital weld the outer tube and helium leak test
- Zusammenschieben der äußeren Sicherheitsrohre, so dass die Naht des Prozessrohres verdeckt wird
- Orbitalschweißung des Sicherheitsrohres mit anschließendem Helium-Leck-Test

## Closing the outer safety tube

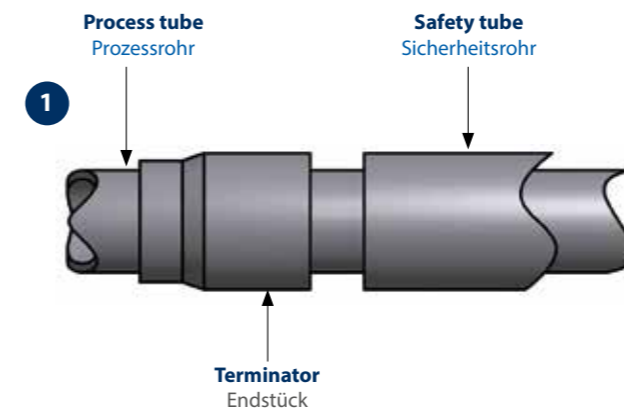

## Abschluss des Schutzrohres

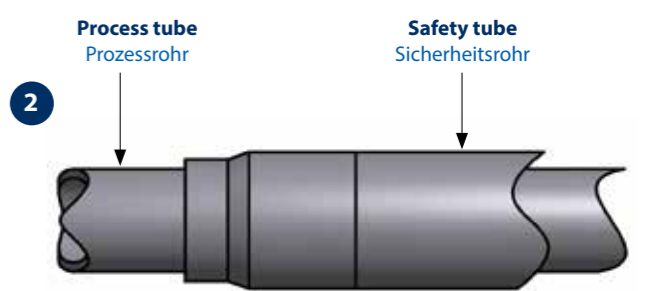

**Orbital weld the terminator to the process tube**  
Orbitalschweißung des Endstückes auf das Prozessrohr

## Fitting to fitting

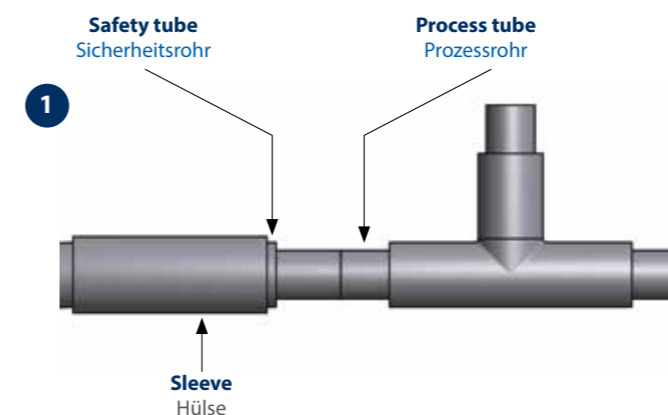

**Orbital weld the process tube**  
Orbitalschweißung des Prozessrohres

## Formteil an Formteil

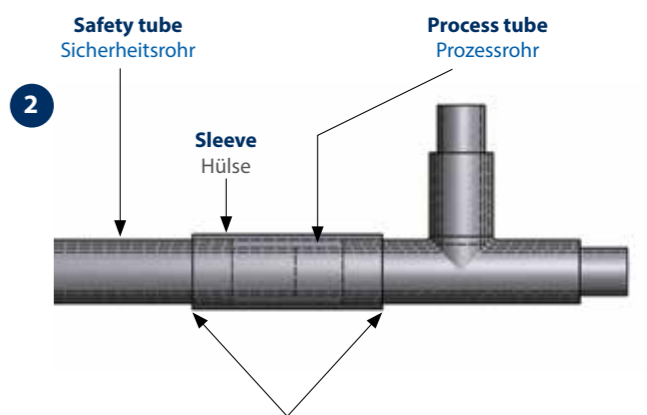

**A sleeve is slid over both ends of the safety tube and orbital welded**  
Eine Hülse wird über beide Rohrenden des Sicherheitsrohres geschoben und orbital verschweißt

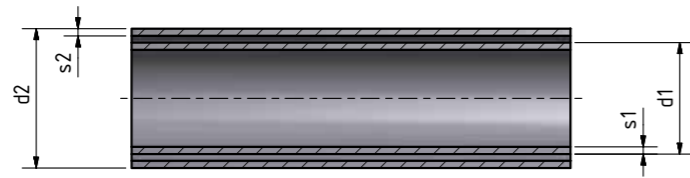

Imperial	Inner Tube Innenrohr		Outer Tube Außenrohr		Weight* Gewicht*
	d1	s1	d2	s2	
Inch / Zoll	mm				kg/m
1/4	6,35	0,89	12,70	1,24	0,4752
3/8	9,53	0,89	15,88	1,24	0,6512
1/2	12,70	1,24	19,05	1,65	1,0709
3/4	19,05	1,65	25,40	1,65	1,7022
1	25,40	1,65	38,10	1,65	2,4901

\*Temp. 20 to 150 °C; static loading; rating depends on outer tube; for detailed information (e.g. rating of inner tube) please see pressure tables in section "Technical Information"  
\*Temp. 20 bis 150 °C; vorw. ruhende Beanspruchung; Angabe gilt für Außenrohr; detaillierte Informationen (z. B. Angaben für das Innenrohr) finden Sie in den ausführlichen Drucktabellen im Abschnitt „Technische Informationen“

Further dimensions on request. Subject to alteration.  
Weitere Abmessungen auf Anfrage. Technische Änderungen vorbehalten.

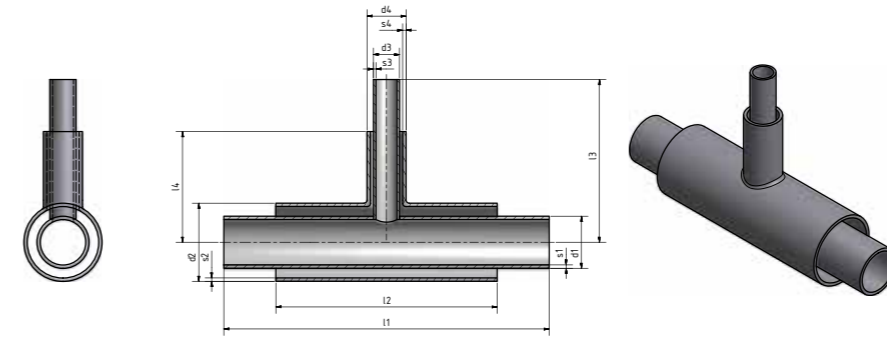

Imperial	Inner Tube Innenrohr				Outer Tube Außenrohr				l1	l2	l3	l4
	Main Tube Durchgang		Branch Abzweig		Main Tube Durchgang		Branch Abzweig					
	d1	s1	d3	s3	d2	s2	d4	s4				
Inch / Zoll	mm											
1/4 x 1/4	6,35	0,89	6,35	0,89	12,70	1,24	12,70	1,24	127,00	88,90	63,50	44,45
3/8 x 1/4	9,53	0,89	6,35	0,89	15,88	1,24	12,70	1,24	127,00	88,90	63,50	44,45
3/8 x 3/8	9,53	0,89	9,53	0,89	15,88	1,24	15,88	1,24	127,00	88,90	63,50	44,45
1/2 x 1/4	12,70	1,24	6,35	0,89	19,05	1,65	12,70	1,24	133,35	95,25	66,68	47,63
1/2 x 3/8	12,70	1,24	9,53	0,89	19,05	1,65	15,88	1,24	133,35	95,25	66,68	47,63
1/2 x 1/2	12,70	1,24	12,70	1,24	19,05	1,65	19,05	1,65	133,35	95,25	66,68	47,63
3/4 x 1/4	19,05	1,65	6,35	0,89	25,40	1,65	12,70	1,24	133,35	95,25	66,68	47,63
3/4 x 3/8	19,05	1,65	9,53	0,89	25,40	1,65	15,88	1,24	133,35	95,25	66,68	47,63
3/4 x 1/2	19,05	1,65	12,70	1,24	25,40	1,65	19,05	1,65	133,35	95,25	66,68	47,63
3/4 x 3/4	19,05	1,65	19,05	1,65	25,40	1,65	25,40	1,65	133,35	95,25	66,68	47,63
1 x 1/4	25,40	1,65	6,35	0,89	38,10	1,65	12,70	1,24	158,75	107,95	79,38	53,98
1 x 3/8	25,40	1,65	9,53	0,89	38,10	1,65	15,88	1,24	158,75	107,95	79,38	53,98
1 x 1/2	25,40	1,65	12,70	1,24	38,10	1,65	19,05	1,65	158,75	107,95	79,38	53,98
1 x 3/4	25,40	1,65	19,05	1,65	38,10	1,65	25,40	1,65	158,75	107,95	79,38	53,98
1 x 1	25,40	1,65	25,40	1,65	38,10	1,65	38,10	1,65	158,75	107,95	79,38	53,98

Further dimensions on request. Subject to alteration.  
Weitere Abmessungen auf Anfrage. Technische Änderungen vorbehalten.

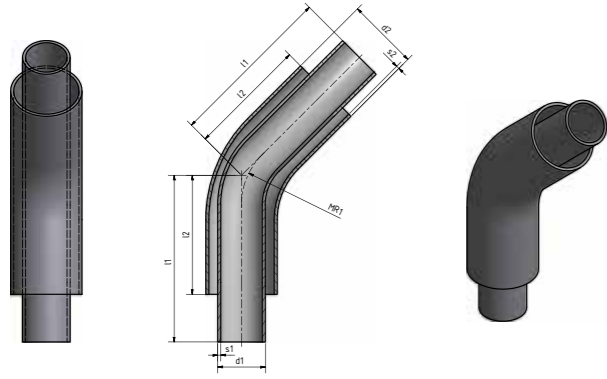

Imperial	Inner Tube Innenrohr		Outer Tube Außenrohr		Dimensions Abmessungen			
	d1	s1	d2	s2	l1	l2	MR1	
Inch / Zoll	mm							
1/4	6,35	0,89	12,70	1,24	98,45	79,40	38,10	bended / gebogen
3/8	9,53	0,89	15,88	1,24	98,45	79,40	57,00	bended / gebogen
1/2	12,70	1,24	19,05	1,65	109,26	90,21	85,00	bended / gebogen
3/4	19,05	1,65	25,40	1,65	135,61	110,21	85,00	bended / gebogen
1	25,40	1,65	38,10	1,65	88,90	63,50	38,10	welded / geschweißt

Further dimensions on request. Subject to alteration.  
Weitere Abmessungen auf Anfrage. Technische Änderungen vorbehalten.

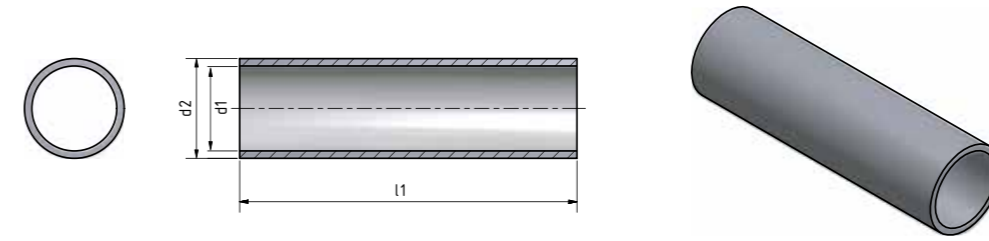

Imperial	Inner Tube Innenrohr	Outer Tube Außenrohr	Sleeve Hülse		
	d	d	d1	d2	l1
Inch / Zoll	mm				
1/4	6,35	12,70	12,90	15,88	101,60
3/8	9,53	15,88	16,11	19,05	101,60
1/2	12,70	19,05	19,30	22,23	101,60
3/4	19,05	25,40	25,60	30,00	101,60
1	25,40	38,10	38,40	42,40	101,60

Further dimensions on request. Subject to alteration.  
Weitere Abmessungen auf Anfrage. Technische Änderungen vorbehalten.

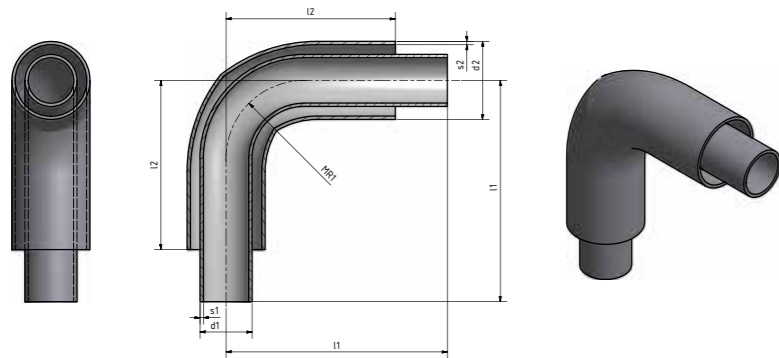

Imperial	Inner Tube Innenrohr		Outer Tube Außenrohr		Dimensions Abmessungen			
	d1	s1	d2	s2	l1	l2	MR1	
Inch / Zoll	mm							
1/4	6,35	0,89	12,70	1,24	120,70	101,65	38,10	bended / gebogen
3/8	9,53	0,89	15,88	1,24	130,70	111,65	57,00	bended / gebogen
1/2	12,70	1,24	19,05	1,65	184,40	165,35	85,00	bended / gebogen
3/4	19,05	1,65	25,40	1,65	190,75	165,35	85,00	bended / gebogen
1	25,40	1,65	38,10	1,65	107,97	82,57	38,10	welded / geschweißt

Further dimensions on request. Subject to alteration.  
Weitere Abmessungen auf Anfrage. Technische Änderungen vorbehalten.

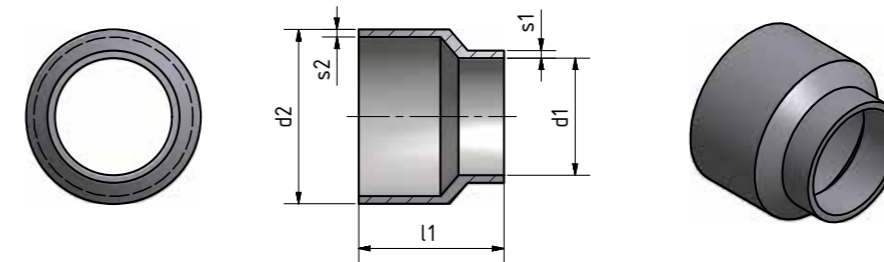

Imperial	Dimensions Abmessungen		
	d1	d2	l1
Inch / Zoll	mm		
1/4	6,35	12,70	25,40
3/8	9,53	15,88	25,40
1/2	12,70	19,05	25,40
3/4	19,05	25,40	31,75
1	25,40	38,10	31,75

Further dimensions on request. Subject to alteration.  
Weitere Abmessungen auf Anfrage. Technische Änderungen vorbehalten.



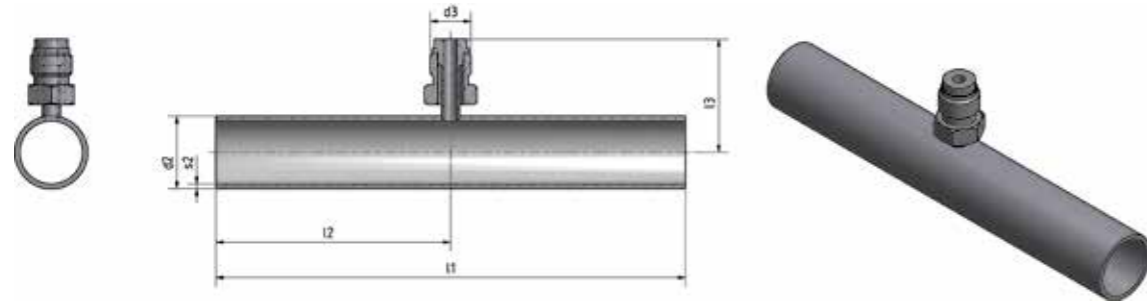

Imperial	Inner Tube* Innenrohr*		Outer Tube Außenrohr		VCR**			
	d2	s2	l1	l2	l3	d3		
Inch / Zoll	mm		Inch / Zoll					
1/4	6,35	0,89	12,70	1,24	146,00	73,00	33,30	1/4
3/8	9,53	0,89	15,88	1,24	152,40	76,20	34,80	1/4
1/2	12,70	1,24	19,05	1,65	152,40	76,20	36,40	1/4
3/4	19,05	1,65	25,40	1,65	165,10	82,55	39,60	1/4
1	25,40	1,65	38,10	1,65	165,10	82,55	45,85	1/4

\* The inner tube is not part of the scope of delivery.  
\* Das Innenrohr ist nicht im Lieferumfang enthalten.

\*\* Trademark

Further dimensions on request. Subject to alteration.  
Weitere Abmessungen auf Anfrage. Technische Änderungen vorbehalten.

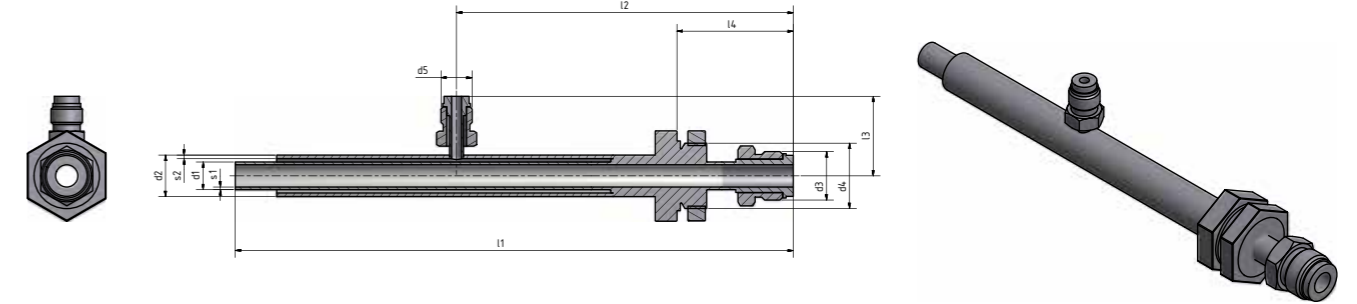

Imperial	Main tube Durchgangsrohr								Branch Abzweig	Straight thread size Gewindeabmessung		
	d1	s1	d2	s2	l1	l2	l3	l4				
Inch / Zoll	mm								VCR* Size Kopfgröße	VCR* tube size Stutzen-Rohranschl.	VCR* Size Kopfgröße	d4
									d3	d5	Inch / Zoll	
1/4	6,35	0,89	12,70	1,24	242,90	144,50	33,15	55,00	1/4	1/4	1/4	M20 x 1,5
3/8	9,53	0,89	15,88	1,24	256,20	154,60	34,80	53,40	1/2	1/4	1/4	M30 x 2
1/2	12,70	1,24	19,05	1,65	256,20	154,60	36,40	53,40	1/2	1/4	1/4	M30 x 2

\* Trademark

Further dimensions on request. Subject to alteration.  
Weitere Abmessungen auf Anfrage. Technische Änderungen vorbehalten.

(Wall aperture /  
Wandöffnung)

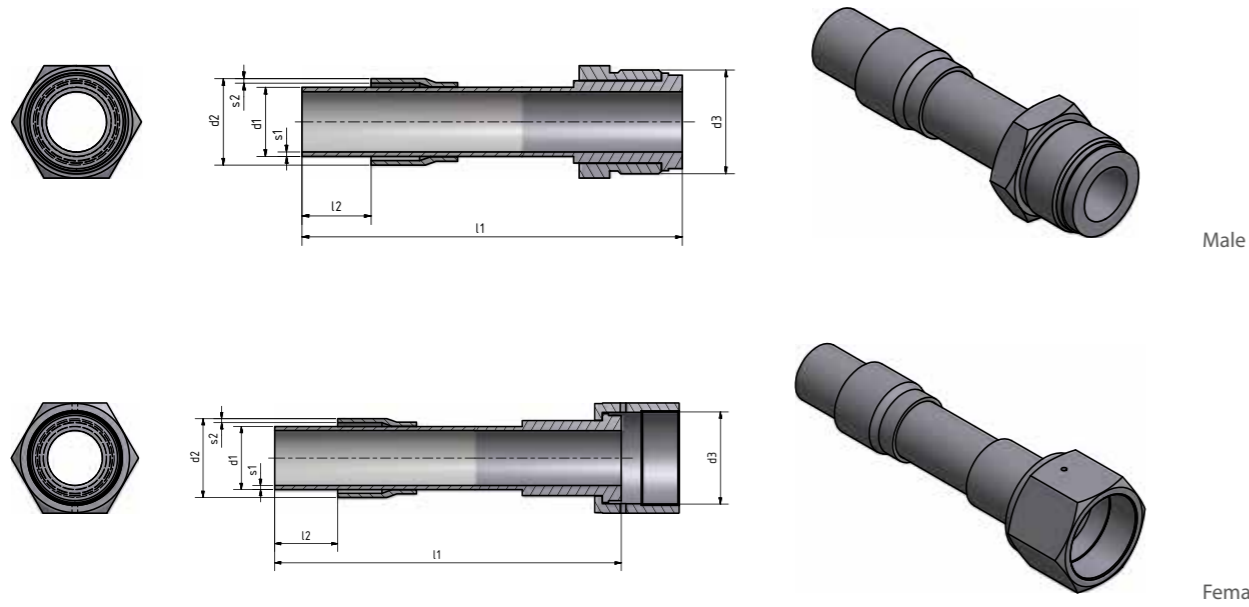

Male

Female



Imperial	Dimensions Abmessungen						VCR* Size Kopfgröße
	d1	s1	d2	s2	l1	l2	d3
Inch / Zoll	mm						Inch / Zoll
1/4	6,35	0,89	12,70	1,24	88,90	19,05	1/4
3/8	9,53	0,89	15,88	1,24	88,90	19,05	1/2
1/2	12,70	1,24	19,05	1,65	88,90	19,05	1/2
3/4	19,05	1,65	25,40	1,65	139,70	25,40	3/4
1	25,40	1,65	38,10	1,65	139,70	25,40	1

\* Trademark

Further dimensions on request. Subject to alteration.  
Weitere Abmessungen auf Anfrage. Technische Änderungen vorbehalten.





# TECHNICAL HOSES TECHNISCHE SCHLÄUCHE

Type / Ausführung	PolyFlow ST	PolyFlow STR
		
<b>Material / Werkstoff</b>	<b>Platinum-cured silicone, braid-reinforced</b>  Platinvernetztes Silikon, textilverstärkt	<b>Platinum-cured silicone, braid-reinforced, with stainless steel wire reinforcement</b>  Platinvernetztes Silikon, textilverstärkt und mit Edelstahldrahtbewehrung
<b>Diameter / Nennweite</b>	1/4" - 1" *	1/2" - 2" *
<b>Max. Length / max. Länge</b>	25 m **	40 m
<b>Min. Bending Radius / min. Biegeradius</b>	40 mm (1/4") - 120 mm (1")	60 mm (1/2") - 210 mm (2")
<b>Temperature Range / Temperaturbereich</b>	-60° bis +180°C	-60° bis +200°C
<b>Working Pressure / Arbeitsdruck</b>	6,0 bar (1/4") - 2,5 bar (1")	6,5 bar (1/2") - 5,5 bar (2")
<b>Conformity / Validierung</b>	FDA 21 CFR 177.2600, BhVV Type II, USP Class VI, USP Physicochemical 661, Cytotoxicity, Hemolysis, European Pharmacopeia 3.1.9	FDA 21 CFR 177.2600, USP Class VI, 3-A Sanitary Standard, EC 1935/2004, EC 2023/2006, DM21/03/1973, BfR XV and XXI cat.2, ISO10993-8, -10 and -11

\* Other dimensions on request. / Weitere Abmessungen auf Anfrage.

\*\* From a diameter of 25 mm only 10 m / Ab einem Durchmesser von 25 mm nur 10 m

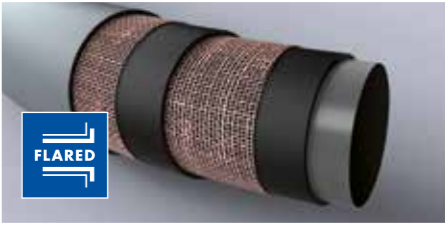
PolyFlow ETR EPDM	PolyFlow PTR	PolyFlow PTR OHM
		
<b>Braid-reinforced with stainless steel wire reinforcement, outside blue EPDM, inside food-grade white EPDM</b>  Textilverstärkt mit Edelstahldrahtbewehrung, blaues EPDM, innen lebensmittelgeeignetes weißes EPDM	<b>Teflon® (PTFE) liner (white), braid-reinforced (&gt;1" also stainless steel wire reinforcement), outside EPDM</b>  Teflon® (PTFE)-Liner (weiß), gewebeverstärkt (>1" mit Edelstahlbewehrung), außen EPDM	<b>Teflon® (PTFE) liner (black), braid-reinforced (&gt;1" also stainless steel wire reinforcement), outside EPDM, fully electrically conductive (Ω/T)</b>  Teflon® (PTFE)-Liner (weiß), gewebeverstärkt (>1" mit Edelstahlbewehrung), außen EPDM, elektrisch leitfähig (Ω/T).
3/4" - 2" *	1/2" - 2"	1/2" - 2"
10 m	40 m	40 m
120 mm (3/4") - 300 mm (2")	110 mm (1/2") - 210 mm (2")	110 mm (1/2") - 210 mm (2")
-30° bis +120°C	-30° bis +150°	-30° bis +150°C
6,5 bar (3/4") - 4,0 bar (2")	6,5 bar	6,5 bar
FDA 21 CFR - 177.2600, BGVV Type II, USP Physicochemical 661	FDA 21 CFR 177.1550, FDA 21 CFR 1783297, USP Class VI, EC 1935/2004, 10/2011, 1282/2011, 1183/2011, 202/2014, 2023/2006, BedGgstV, 24.06.2013, LFGB	FDA 21 CFR 177.1550, FDA 21 CFR 1783297, USP Class VI, EC 1935/2004, 10/2011, 1282/2011, 1183/2011, 202/2014, 2023/2006, Bed.Ggst V, 24.06.2013, LFGB

**Available connections:**

- TriClamp connections in accordance with DIN 32676 and ASME BPE 2019
- Aseptic connections in accordance with DIN 11864 Form A
- Welding ends for orbital welding
- Further connections and customized solutions (e.g. 90° Elbow) on request
- **Free of dead space due to specially crimped hose fitting FLARED:** PolyFlow PTR and PolyFlow PTR OHM hoses with crimped hose-fitting and flared PTFE liner. The connection fitting has no contact to the medium, as the special crimping does not allow for any gaps or dead space up to the seal.

**Verfügbare Anschlüsse:**

- TriClamp-Verbindungen gem. DIN 32676 bzw. ASME BPE 2019
- Aseptik-Verbindungen gemäß DIN 11864 Form A
- Anschweißenden zum Orbitalschweißen
- Weitere Verbindungen und Sonderlösungen (z.B. 90° Bögen) auf Anfrage.
- **Totraumfrei mit speziell verpresster Schlaucharmatur „FLARED“:** PolyFlow-PTR „FLARED“ und PolyFlow-PTR OHM „FLARED“ mit verpresster Schlaucharmatur und umbördeltem PTFE-Liner an. Die Anschlussarmatur hat keinen Kontakt zum Medium, da die spezielle Verpressung keinen Spalt oder Totraum bis zur Dichtung zulässt.

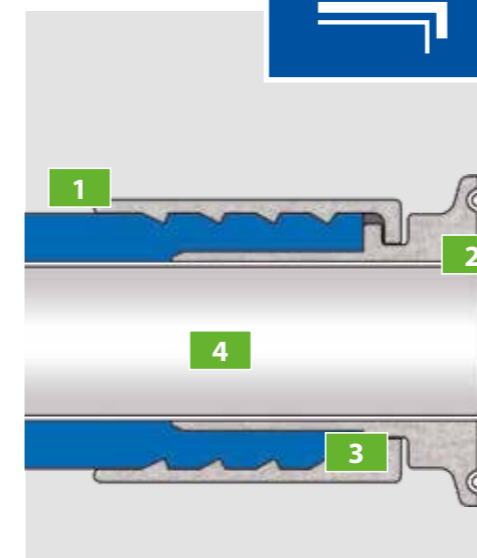

**FLARED connection / FLARED Anschluss:**

- 1 PolyFlow PTR / PolyFlow PTR OHM
- 2 Hose fittings / Schlaucharmatur
- 3 Patented sheath specification patentierte Mantel-Fixierung
- 4 PTFE-Liner (Teflon®)

**Corrugated hoses in stainless steel**

Dockweiler Flextron are electropolished, clean room cleaned corrugated hoses in ultron quality. Flextron has been developed for the highest demands in the supply of high purity gas systems.

**Lengths and connections**

Flextron is available in the following standard lengths: 6" (150 mm), 12" (300 mm), 24" (600 mm) and 36" (900 mm). Others are available on request.

Flextron is generally available with VCR or orbital weld ends. Other connection options are available on request.

**Edelstahl-Wellschläuche**

Dockweiler Flextron sind elektropolierte, reinraumgereinigte Wellschläuche in ultron Qualität. Flextron ist für die höchsten Ansprüche in der Reinstgasversorgung entwickelt worden.

**Längen und Anschlüsse**

Flextron ist in folgenden Standardlängen verfügbar: 150 mm (6"), 300 mm (12"), 600 mm (24") und 900 mm (36"). Weitere Längen sind auf Anfrage möglich.

Flextron ist im Standard mit VCR oder Orbitalweißenden ausgestattet. Weitere Anschlussvarianten sind auf Anfrage möglich.

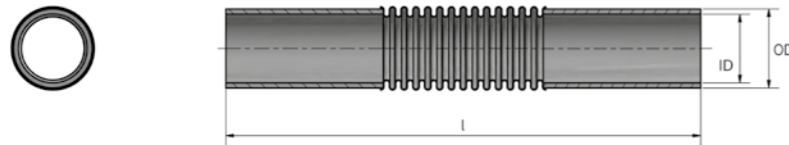

ultron	Imperial		Type	OD / AD	ID	Minimum Bending radius static <sup>1</sup> Minimaler statischer Biegeradius <sup>1</sup>	Bending radius dynamic <sup>1</sup> Dynamischer Biegeradius <sup>1</sup>	Pressure rating <sup>1</sup> Druck <sup>1</sup>	Weight Gewicht
	Inch	mm							
•	1/4	6,35	not braided / nicht ummantelt	10,2	6,2	25	140	18	0,12
			braided / ummantelt	11,6	6,2	25	140	80	0,23
•	3/8	9,53	not braided / nicht ummantelt	10,2	6,2	25	140	18	0,12
			braided / ummantelt	11,6	6,2	25	140	80	0,23
•	1/2	12,70	not braided / nicht ummantelt	14,3	10,2	38	190	8	0,11
			braided / ummantelt	15,7	10,2	38	190	80	0,23
•	3/4	19,05	not braided / nicht ummantelt	26,7	20,2	70	285	3	0,27
			braided / ummantelt	28,3	20,2	70	285	45	0,49
•	1	25,40	not braided / nicht ummantelt	26,7	20,2	70	285	3	0,27
			braided / ummantelt	28,3	20,2	70	285	45	0,49

<sup>1</sup> Tested acc. ISO 10380 at room Temperature (20°C) / Geprüft nach ISO 10380 bei Raumtemperatur (20°C)



# GENERAL INFORMATION

## ALLGEMEINE INFORMATIONEN



Benefit from our expertise, our products and our services. For smooth installations.

Profitieren Sie von unserem Know-how, unseren Produkten und unseren Dienstleistungen. Für reibungslose Installationen.

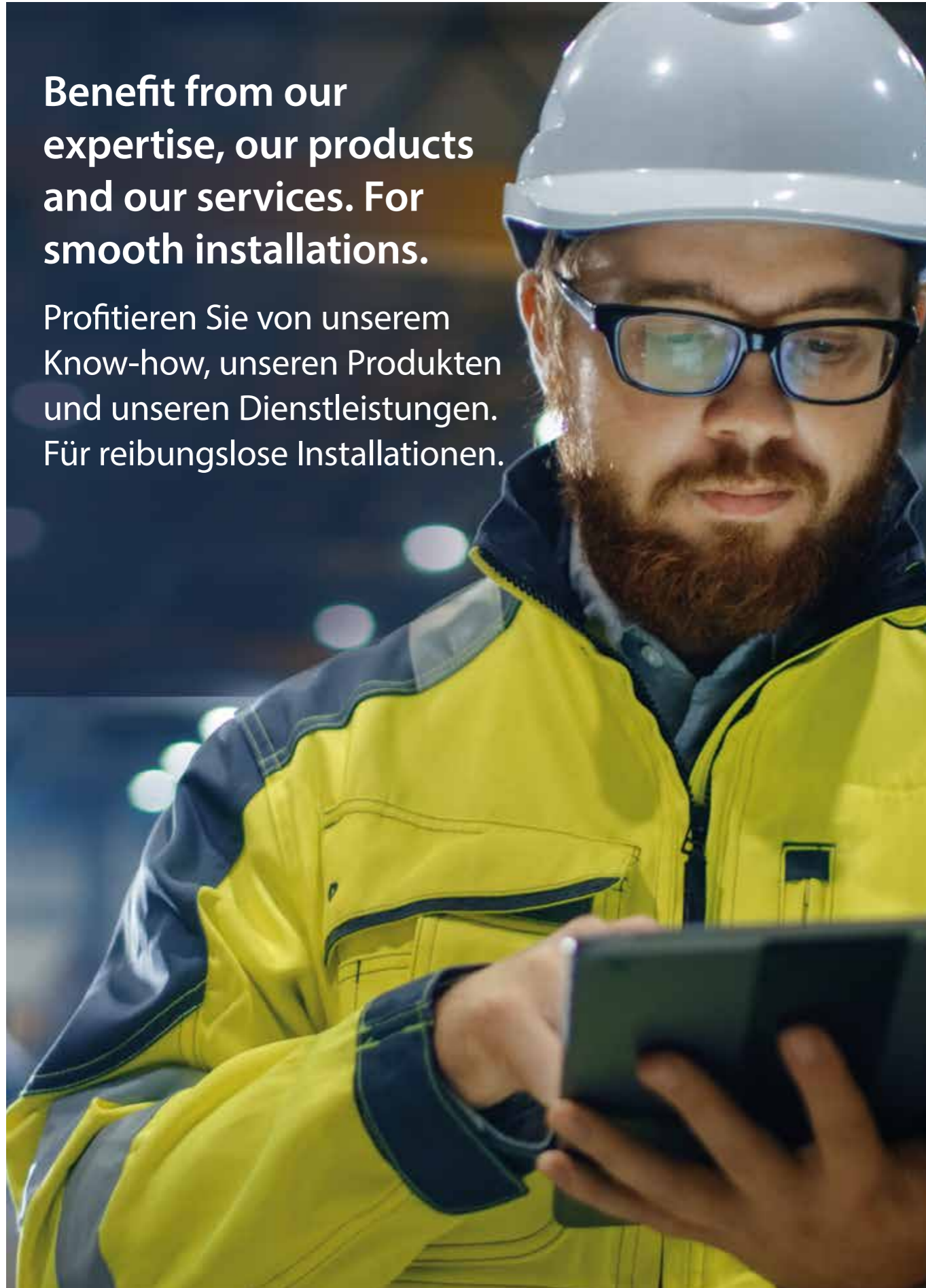

Large stock for high delivery reliability

Großer Lagerbestand für eine hohe Liefertreue

Specific inner surfaces for safe installations

Spezifische Innenoberflächen für sichere Installationen



Highest purity up to Ra 0.13 µm

Höchste Reinheit bis zu einem Ra-Wert von 0,13 µm



Weld seams in perfection and ultimate quality

Schweißnähte in höchster Perfektion und Qualität



Engineered components for enhanced efficiency

Maßgeschneiderte Bauteile für mehr Arbeitseffizienz





Dockweiler quality  
no matter what  
Dockweiler-Qualität: immer erster Klasse

Outstanding inspection:  
up to 50 tests per component  
Maximale Kontrolle:  
bis zu 50 Tests pro Bauteil



End-to-end documentation  
and traceability  
Lückenlose Dokumentation  
und Rückverfolgbarkeit der Produkte

Consistent 3.1 certificates  
with all important information  
Einheitliche 3.1-Zeugnisse  
mit allen wichtigen Informationen



Easy document management:  
online with WebCert  
Komfortables Dokumentenmanagement:  
online mit WebCert

**Highest quality from raw material to delivery.**  
Höchste Qualität vom Rohmaterial  
bis zur Auslieferung.

All certificates are available on our website:  
Alle Zertifikate finden Sie auf unserer Webseite:  
[www.dockweiler.com](http://www.dockweiler.com)



ASME BPE



DIN EN ISO 9001



DIN EN ISO 14001



DGR 104/68/EU and AD 2000 WO



AD 2000 HPO

Imperial		Wall Thickness / Wandstärke <sup>a)</sup>		Standard for tube tolerances / Normen für Rohrtoleranzen <sup>b)</sup> ASTM A 269 / A 270 <sup>c)</sup> / A 632 / ASME BPE Max. allowable working pressure / Max. zulässiger Betriebsdruck			
				100°F (38°C)	200°F (93°C)	300°F (149°C)	400°F (204°C)
[inch]	[mm]	[inch]	[mm]	[psi]	[psi]	[psi]	[psi]
1/8	3,18	0,022	0,56	4716	4716	4716	4434
1/4	6,35	0,035	0,89	3678	3678	3678	3458
3/8	9,53	0,035	0,89	2378	2378	2378	2236
1/2	12,70	0,049	1,24	2508	2508	2508	2358
1/2	12,70	0,065	1,65	3203	3203	3203	3011
5/8	15,88	0,049	1,24	1981	1981	1981	1862
3/4	19,05	0,049	1,24	1637	1637	1637	1539
3/4	19,05	0,065	1,65	2207	2207	2207	2075
1	25,40	0,065	1,65	1631	1631	1631	1533
1 1/4	31,75	0,065	1,65	1293	1293	1293	1216
1 1/2	38,10	0,065	1,65	1069	1069	1069	1005
2	50,80	0,065	1,65	797	797	797	749
2 1/2	63,50	0,065	1,65	634	634	634	596
3	76,20	0,065	1,65	527	527	527	495
4	101,60	0,083	2,11	504	504	504	474
6	152,40	0,109	2,77	440	440	440	414

ISO		Wall Thickness / Wandstärke <sup>a)</sup>		Standard for tube tolerances / Normen für Rohrtoleranzen <sup>b)</sup> DIN EN ISO 1127, D4/T3 Max. allowable working pressure / Max. zulässiger Betriebsdruck			
				100°F (38°C)	200°F (93°C)	300°F (149°C)	400°F (204°C)
[mm]	[mm]	[psi]	[psi]	[psi]	[psi]	[psi]	[psi]
13,50	1,60	2997	2997	2997	2997	2997	2817
17,20	1,60	2311	2311	2311	2311	2311	2173
21,30	1,60	1843	1843	1843	1843	1843	1733
26,90	1,60	1443	1443	1443	1443	1443	1357
33,70	2,00	1483	1483	1483	1483	1483	1394
42,40	2,00	1168	1168	1168	1168	1168	1098
48,30	2,00	1021	1021	1021	1021	1021	959
60,30	2,00	812	812	812	812	812	764
76,10	2,00	640	640	640	640	640	602
88,90	2,30	630	630	630	630	630	592
114,30	2,30	488	488	488	488	488	459
139,70	2,30	398	398	398	398	398	374
168,30	2,60	373	373	373	373	373	351
219,10	2,60	286	286	286	286	286	269

The listed ratings apply to seamless tube UNS S31603 acc. to ASME SA213, welded tube UNS S31603 acc. to ASME SA249, and seamless and welded pipe UNS 31603 acc. to ASTM A 312, Weld Joint Strength Reduction Factor W = 1, Basic Quality Factor for Longitudinal Weld Joints in Pipes and Tubes Ej = 0,8 A zero corrosion allowance is specified. Die angegebenen Werte gelten für nahtlose Rohre aus Werkstoff UNS S31603 gem. ASME SA213 sowie für längsnaht-geschweißte Rohre aus Werkstoff UNS S31603 gem. ASME SA249, Weld Joint Strength Reduction Factor W = 1, Basic Quality Factor for Longitudinal Weld Joints in Pipes and Tubes Ej = 0,8. Die Berechnung erfolgte ohne Korrosionszuschläge.

<sup>a)</sup> Calculation of maximum permissible design pressure is based on the data given in [inch], data given in [mm] are for information only.  
 Für die Berechnung des max. zulässigen Betriebsdrucks wurden die Maße in [inch] zugrunde gelegt, die Angaben in [mm] sind informativ.

<sup>b)</sup> All referenced standards shall be met / Alle angegebenen Normen sind einzuhalten

<sup>c)</sup> ASTM A 270, S2. Pharmaceutical Quality Tubing

Further pressure ratings are available on our website / Weitere Druckangaben finden Sie auf unserer Webseite: [www.dockweiler.com/downloads](http://www.dockweiler.com/downloads)

Metric		Wall Thickness / Wandstärke <sup>a)</sup>		Standard for tube tolerances / Normen für Rohrtoleranzen <sup>b)</sup> DIN EN ISO 1127, D4/T3 Max. allowable working pressure / Max. zulässiger Betriebsdruck			
				100°F (38°C)	200°F (93°C)	300°F (149°C)	400°F (204°C)
[mm]	[mm]	[psi]	[psi]	[psi]	[psi]	[psi]	[psi]
3,00	0,50	2802	2802	2802	2802	2802	2634
6,00	1,00	3915	3915	3915	3915	3915	3680
8,00	1,00	2865	2865	2865	2865	2865	2693
10,00	1,00	2259	2259	2259	2259	2259	2124
12,00	1,00	1865	1865	1865	1865	1865	1753
13,00	1,50	2880	2880	2880	2880	2880	2707
15,00	1,50	2470	2470	2470	2470	2470	2322
18,00	1,50	2036	2036	2036	2036	2036	1914
19,00	1,50	1923	1923	1923	1923	1923	1808
22,00	1,50	1648	1648	1648	1648	1648	1549
23,00	1,50	1573	1573	1573	1573	1573	1479
28,00	1,50	1281	1281	1281	1281	1281	1205
29,00	1,50	1235	1235	1235	1235	1235	1161
34,00	1,50	1048	1048	1048	1048	1048	985
35,00	1,50	1017	1017	1017	1017	1017	956
40,00	1,50	887	887	887	887	887	833
41,00	1,50	864	864	864	864	864	813
52,00	1,50	678	678	678	678	678	637
53,00	1,50	665	665	665	665	665	625
70,00	2,00	697	697	697	697	697	656
85,00	2,00	572	572	572	572	572	538
104,00	2,00	466	466	466	466	466	438
129,00	2,00	375	375	375	375	375	352
154,00	2,00	313	313	313	313	313	294
204,00	2,00	236	236	236	236	236	222

The listed ratings apply to seamless tube UNS S31603 acc. to ASME SA213, welded tube UNS S31603 acc. to ASME SA249, and seamless and welded pipe UNS 31603 acc. to ASTM A 312, Weld Joint Strength Reduction Factor W = 1, Basic Quality Factor for Longitudinal Weld Joints in Pipes and Tubes Ej = 0,8 A zero corrosion allowance is specified. Die angegebenen Werte gelten für nahtlose Rohre aus Werkstoff UNS S31603 gem. ASME SA213 sowie für längsnaht-geschweißte Rohre aus Werkstoff UNS S31603 gem. ASME SA249, Weld Joint Strength Reduction Factor W = 1, Basic Quality Factor for Longitudinal Weld Joints in Pipes and Tubes Ej = 0,8. Die Berechnung erfolgte ohne Korrosionszuschläge.

<sup>a)</sup> Calculation of maximum permissible design pressure is based on the data given in [inch], data given in [mm] are for information only.  
 Für die Berechnung des max. zulässigen Betriebsdrucks wurden die Maße in [inch] zugrunde gelegt, die Angaben in [mm] sind informativ.

<sup>b)</sup> All referenced standards shall be met / Alle angegebenen Normen sind einzuhalten

<sup>c)</sup> ASTM A 270, S2. Pharmaceutical Quality Tubing

Further pressure ratings are available on our website / Weitere Druckangaben finden Sie auf unserer Webseite: [www.dockweiler.com/downloads](http://www.dockweiler.com/downloads)

Imperial		Wall Thickness / Wandstärke <sup>a)</sup>		Standard for tube tolerances / Normen für Rohrtoleranzen <sup>b)</sup> ASTM A 269 / A 270 <sup>c)</sup> / A 632 / ASME BPE Max. allowable working pressure / Max. zulässiger Betriebsdruck			
				20°C	50°C	100°C	150°C
[inch]	[mm]	[mm]	[inch]	[bar]	[bar]	[bar]	[bar]
1/8	3,18	0,56	0,022	548	529	485	439
1/4	6,35	0,89	0,035	424	409	375	339
3/8	9,53	0,89	0,035	271	262	240	217
1/2	12,70	1,24	0,049	287	276	253	229
1/2	12,70	1,65	0,065	368	355	325	294
5/8	15,88	1,24	0,049	225	217	199	180
3/4	19,05	1,24	0,049	186	179	164	148
3/4	19,05	1,65	0,065	251	243	222	201
1	25,40	1,65	0,065	185	178	163	148
1 1/4	31,75	1,65	0,065	146	141	129	117
1 1/2	38,10	1,65	0,065	121	116	107	96
2	50,80	1,65	0,065	90	86	79	72
2 1/2	63,50	1,65	0,065	71	69	63	57
3	76,20	1,65	0,065	59	57	52	47
4	101,60	2,11	0,083	56	54	50	45
6	152,40	2,77	0,109	49	47	43	39

ISO		Wall Thickness / Wandstärke <sup>a)</sup>		Standard for tube tolerances / Normen für Rohrtoleranzen <sup>b)</sup> DIN EN ISO 1127, D4/T3 Max. allowable working pressure / Max. zulässiger Betriebsdruck			
				20°C	50°C	100°C	150°C
[mm]	[mm]	[mm]	[mm]	[bar]	[bar]	[bar]	[bar]
13,50	1,60	1,60	1,60	344	332	304	275
17,20	1,60	1,60	1,60	264	254	233	211
21,30	1,60	1,60	1,60	209	202	185	167
26,90	1,60	1,60	1,60	163	158	144	131
33,70	2,00	2,00	2,00	168	162	148	134
42,40	2,00	2,00	2,00	132	127	117	105
48,30	2,00	2,00	2,00	115	111	102	92
60,30	2,00	2,00	2,00	91	88	81	73
76,10	2,00	2,00	2,00	72	69	63	57
88,90	2,30	2,30	2,30	71	68	62	56
114,30	2,30	2,30	2,30	55	53	48	44
139,70	2,30	2,30	2,30	44	43	39	35
168,30	2,60	2,60	2,60	42	40	37	33
219,10	2,60	2,60	2,60	32	31	28	25

The listed ratings apply to seamless tube UNS S31603 acc. to ASME SA213, welded tube UNS S31603 acc. to ASME SA249, and seamless and welded pipe UNS 31603 acc. to ASTM A 312, Weld Joint Strength Reduction Factor W = 1, Basic Quality Factor for Longitudinal Weld Joints in Pipes and Tubes Ej = 0,8 A zero corrosion allowance is specified. Die angegebenen Werte gelten für nahtlose Rohre aus Werkstoff UNS S31603 gem. ASME SA213 sowie für längsnaht-geschweißte Rohre aus Werkstoff UNS S31603 gem. ASME SA249, Weld Joint Strength Reduction Factor W = 1, Basic Quality Factor for Longitudinal Weld Joints in Pipes and Tubes Ej = 0,8. Die Berechnung erfolgte ohne Korrosionszuschläge.

<sup>a)</sup> Calculation of maximum permissible design pressure is based on the data given in [inch], data given in [mm] are for information only.  
 Für die Berechnung des max. zulässigen Betriebsdrucks wurden die Maße in [inch] zugrunde gelegt, die Angaben in [mm] sind informativ.

<sup>b)</sup> All referenced standards shall be met / Alle angegebenen Normen sind einzuhalten

<sup>c)</sup> ASTM A 270, S2. Pharmaceutical Quality Tubing

Further pressure ratings are available on our website / Weitere Druckangaben finden Sie auf unserer Webseite: [www.dockweiler.com/downloads](http://www.dockweiler.com/downloads)

Metric		Wall Thickness / Wandstärke <sup>a)</sup>		Standard for tube tolerances / Normen für Rohrtoleranzen <sup>b)</sup> DIN EN ISO 1127, D4/T3 Max. allowable working pressure / Max. zulässiger Betriebsdruck			
				20°C	50°C	100°C	150°C
[mm]	[mm]	[mm]	[mm]	[bar]	[bar]	[bar]	[bar]
3,00	0,50	0,50	0,50	321	310	284	257
6,00	1,00	1,00	1,00	452	436	400	362
8,00	1,00	1,00	1,00	328	317	290	263
10,00	1,00	1,00	1,00	258	248	228	206
12,00	1,00	1,00	1,00	212	204	187	169
13,00	1,50	1,50	1,50	330	318	292	264
15,00	1,50	1,50	1,50	282	272	249	226
18,00	1,50	1,50	1,50	232	223	205	185
19,00	1,50	1,50	1,50	219	211	193	175
22,00	1,50	1,50	1,50	187	180	165	149
23,00	1,50	1,50	1,50	178	172	158	143
28,00	1,50	1,50	1,50	145	140	128	116
29,00	1,50	1,50	1,50	140	135	123	112
34,00	1,50	1,50	1,50	118	114	104	94
35,00	1,50	1,50	1,50	115	111	101	92
40,00	1,50	1,50	1,50	100	96	88	80
41,00	1,50	1,50	1,50	97	94	86	78
52,00	1,50	1,50	1,50	76	73	67	61
53,00	1,50	1,50	1,50	75	72	66	60
70,00	2,00	2,00	2,00	78	75	69	63
85,00	2,00	2,00	2,00	64	62	57	51
104,00	2,00	2,00	2,00	52	50	46	42
129,00	2,00	2,00	2,00	42	40	37	33
154,00	2,00	2,00	2,00	35	34	31	28
204,00	2,00	2,00	2,00	26	25	23	21

The listed ratings apply to seamless tube UNS S31603 acc. to ASME SA213, welded tube UNS S31603 acc. to ASME SA249, and seamless and welded pipe UNS 31603 acc. to ASTM A 312, Weld Joint Strength Reduction Factor W = 1, Basic Quality Factor for Longitudinal Weld Joints in Pipes and Tubes Ej = 0,8 A zero corrosion allowance is specified. Die angegebenen Werte gelten für nahtlose Rohre aus Werkstoff UNS S31603 gem. ASME SA213 sowie für längsnaht-geschweißte Rohre aus Werkstoff UNS S31603 gem. ASME SA249, Weld Joint Strength Reduction Factor W = 1, Basic Quality Factor for Longitudinal Weld Joints in Pipes and Tubes Ej = 0,8. Die Berechnung erfolgte ohne Korrosionszuschläge.

<sup>a)</sup> Calculation of maximum permissible design pressure is based on the data given in [inch], data given in [mm] are for information only.  
 Für die Berechnung des max. zulässigen Betriebsdrucks wurden die Maße in [inch] zugrunde gelegt, die Angaben in [mm] sind informativ.

<sup>b)</sup> All referenced standards shall be met / Alle angegebenen Normen sind einzuhalten

<sup>c)</sup> ASTM A 270, S2. Pharmaceutical Quality Tubing

Further pressure ratings are available on our website / Weitere Druckangaben finden Sie auf unserer Webseite: [www.dockweiler.com/downloads](http://www.dockweiler.com/downloads)



## Elements in stainless steels

Steel is one of the most commonly used alloys and consists mainly of iron. In general the carbon content is less than 2%. It contains also other components that may emerge due to the manufacturing process or are added to obtain certain characteristics.

Stainless steels according to EN 10020 are alloyed and unalloyed steels with a special purity level like for example steels with a sulphur and phosphorous content (a so-called iron companion) that is not higher than 0.025%.

Stainless steels are characterized by an amount of chromium of more than 10.5%. Due to that high chromium content a protective and dense passive layer of chromium oxide establishes on the material surface. The term "stainless steel" is therefore misleading since materials cannot be stainless in any field of application.

The right choice of the convenient material is crucial for its application. A variety of steels and alloys have been developed to counteract against the possible forms of corrosion in the different industry branches. The requirement for a suitable, corrosion-resistant use of a material is still the appropriate manufacturing. Regarding the application it is important to know and to assess besides the material also the process parameter like medium, concentration, time and temperature.

## Elemente in Edeltählen

Stahl gehört zu den am häufigsten verwendeten Legierungen und besteht hauptsächlich aus Eisen. Der Kohlenstoffgehalt ist im Allgemeinen kleiner als 2 %. Er enthält auch andere Elemente, die zum Teil beim Herstellungsprozess entstehen oder ihm beigefügt werden, um bestimmte Eigenschaften zu erreichen.

Edelstähle (nach EN 10020) bezeichnen legierte oder nicht legierte Stähle mit besonderem Reinheitsgrad, zum Beispiel Stähle, deren Schwefel- und Phosphorgehalt (sogenannte Eisenbegleiter) 0,025 % nicht überschreitet.

Nichtrostende Stähle zeichnen sich durch einen Anteil von mehr als 10,5 Prozent Chrom aus. Durch diesen hohen Chromanteil bildet sich eine schützende und dichte Passivschicht aus Chromoxid an der Werkstoffoberfläche aus. Der Begriff „nichtrostender Stahl“ ist dabei irreführend, da Werkstoffe nicht unter allen Einsatzgebieten nichtrostend sein können.

Die richtige Auswahl des geeigneten Werkstoffes ist entscheidend für dessen zielgerichtete Einsatzfähigkeit. Um den möglichen Korrosionsformen in den verschiedenen Industriezweigen entgegenzuwirken, sind eine Vielzahl von Stählen und Legierungen entwickelt worden. Die Grundvoraussetzung für einen anspruchsgerechten, korrosionsbeständigen Einsatz eines Werkstoffes ist und bleibt jedoch die sachgerechte Verarbeitung.

Hinsichtlich der Applikation ist es wichtig neben dem Material auch die Prozessparameter Medium, Konzentration, Zeit und Temperatur zu kennen und zu bewerten.

Type	Material*	Short name	AISI	UNS	C	Mn	P	S	SI	Cr	Ni	Mo	W	V	Co	Ti	Cu	N	PREN
Austenite	1.4301	X5CrNi18-10	304	S30400	0,08	2	0,045	0,03	1	17,5-19,5	8,0-10,5	--	--	--	--	--	--	--	19
	1.4306	X2CrNi19-11	304L	S30403	0,03	2	0,045	0,015	1	18,0-20,0	10,0-13,0	--	--	--	--	--	--	--	20
	1.4307	X2CrNi18-9	304L	S30403	0,03	2	0,045	0,015	1	17,5-19,5	8,0-10,5	--	--	--	--	--	--	--	19
	1.4404	X2CrNiMo17-12-2	316L	S31603	0,03	2	0,045	0,015	1	16,5-18,5	10,0-14,5	2,00-2,50	--	--	--	--	--	--	23
	1.4435	X2CrNiMo18-14-3	316L	S31603	0,03	2	0,045	0,015	1	17,0-19,0	12,5-15,0	2,50-3,00	--	--	--	--	--	--	26
	1.4571	X6CrNiMoTi17-12-2	316Ti	S31635	0,08	2	0,045	0,015	1	16,5-18,5	10,0-13,5	2,00-2,50	--	--	--	0,5	--	--	23
Super Austenitic	1.4438	X2CrNiMoN-18-15-4	317L	S31703	0,03	2	0,045	0,03	1	17,5-19,5	13,0-17,0	3,0-4,0	--	--	--	--	--	0,11	29
	1.4539	X1NiCrMoCu25-20-5	904L	N08904	0,02	2	0,03	0,01	0,7	19,0-21,0	24,0-26,0	4,0-5,0	--	--	--	--	1,2 - 2,0	0,15	36
	1.4547	X2 NiCrMoCuN20-18-6	6Mo	S31254	0,02	1	0,03	--	1	19,5-20,5	17,5-18,5	6,0-7,0	--	--	--	--	0,50-1,00	0,18-0,25	42
	1.4529	AL-6XN		N08904	0,03	2	0,03	0,01	0,5	19,0-20,0	24,0-26,0	6,0-7,0	--	--	--	--	--	0,18	42
Duplex	1.4462	X2CrNiMoN22-5-3	318LN	S31803	0,03	2	--	--	1	21,0-23,0	4,5-6,5	2,50-3,5	--	--	--	--	--	0,10-0,22	31
	1.4410	X2CrNiMoN 25-7-4	F53	S32750	0,02	2	0,035	0,015	1	25	7	4	--	--	--	--	--	0,27	43
	1.4547	254 SMO	S31254	S31254	0,01	1	0,03	0,01	1	20	18	6,1	--	--	--	--	--	0,2	42
Nickel based alloy	2.4602	Hastelloy C-22	C22	N06022	0,01	0,5	--	--	0,08	22	56	13	3	0,35	2,5	0	0	0	46
	2.4819	Hastelloy C-276	C276	N10276	0,01	1	0,025	0,01	0,08	14,5	57	15	3	0,35	2,5	0	0	0	45

### Pitting Resistance Equivalent (PREN)

Steel PREN = %Cr + 3,3 x %Mo + 16 x %N

Nickel based Alloy PREN = %Cr + 1,5 x (%Mo + %W + Nb)

Seawater resistance PREN ≥ 40

\* Not all materials available from stock / Nicht alle Materialien ab Lager lieferbar

## Welded and seamless tubes

**Welded tubes** are tubes that have a wall thickness that is small in relation to their outside diameter. Steel is bent into a tube by mechanical forming and welded at the joints.

**Seamless tubes** with diameters of about 200 mm with large wall thicknesses are usually produced seamlessly. In the continuous casting process, a non-ferrous tube is formed and immediately reduced in diameter by rolling. Seamless tubes can also be produced by plastic forming.

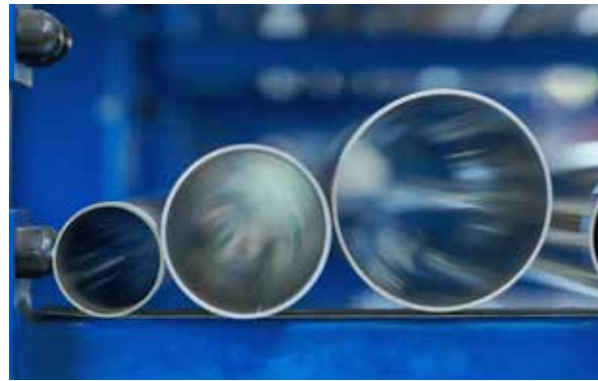

## Geschweißte und nahtlose Rohre

**Geschweißte Rohre** sind Rohre, die eine mit geringe Wanddicke im Verhältnis zu ihrem Außendurchmesser haben. Durch mechanische Umformung wird Stahl zu einem Rohr gebogen und an den Stößen verschweißt.

**Nahtlose Rohre** mit Durchmesser von ca. 200 mm mit großen Wandstärken werden meist nahtlos produziert. Im Strangguss-Verfahren wird ein Nichteisenrohr geformt, das sofort durch Walzen im Durchmesser reduziert wird. Nahtlose Rohre können auch durch plastisches Umformen hergestellt werden.

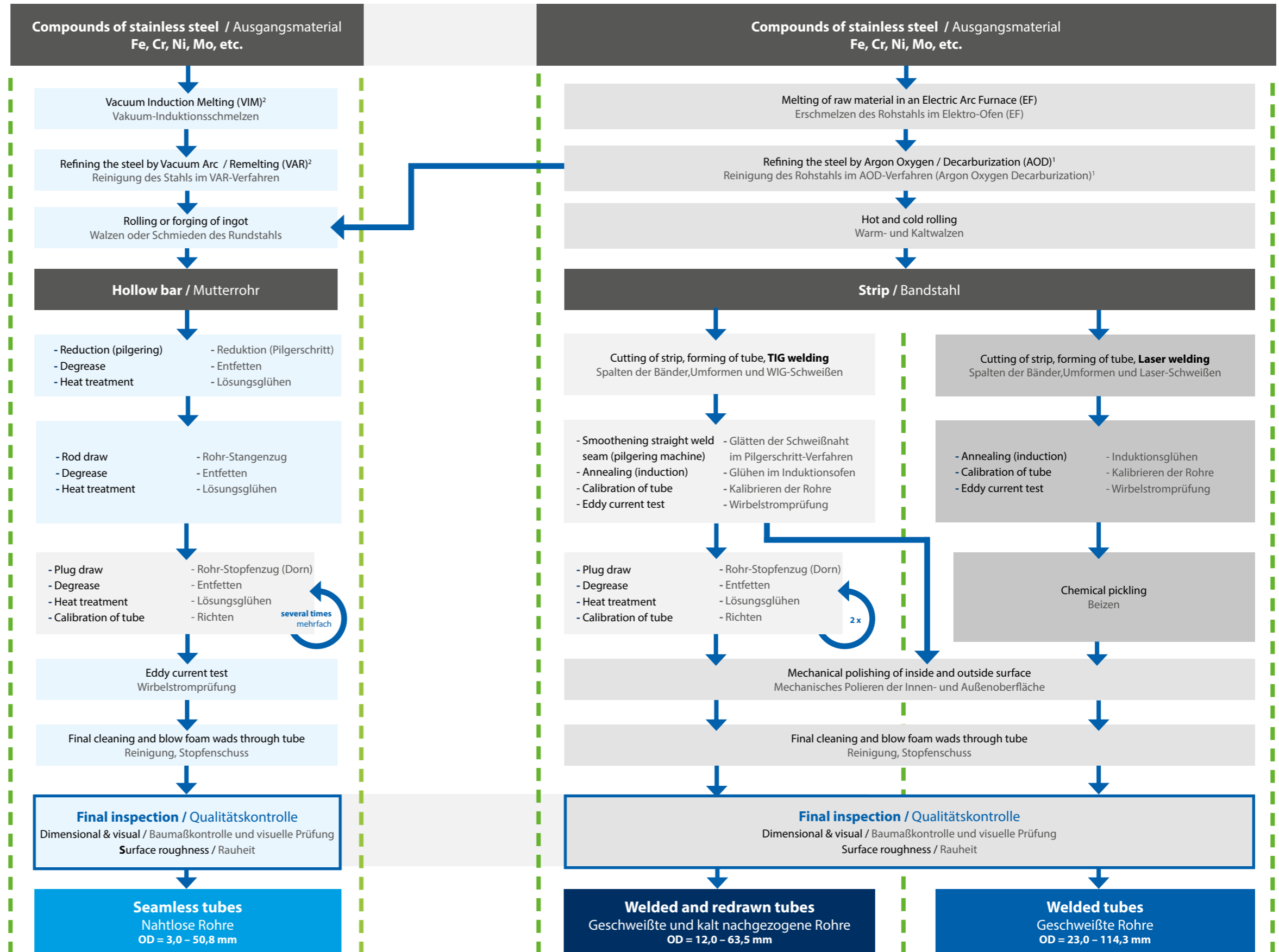

<sup>1</sup> Alternatively Vacuum Oxygen Decarburization (VOD) is applied for refining instead of AOD  
<sup>1</sup> Alternativ zum AOD-Prozeß wird im Induktionsofen auch unter Vakuum umgeschmolzen (VOD)

<sup>2</sup> Base material for Ultron LM  
<sup>2</sup> Basismaterial für Ultron LM



## Cleaning Processes: For various industrial applications

Different industries and application areas have different requirements for the cleanliness of media contact surfaces. Thus Dockweiler offers a variety of different cleaning processes. From cleaning internal surfaces in accordance to ASTM A632, S3 or dry cleaning processes. Up to the most high-tech ultra pure and proprietary vacuum cleaning process with subsequent residual gas analysis. With our cleaning processes we ensure the cleaning of highly complex geometries and even capillary structures.

## Reinigungsverfahren: Für unterschiedliche industrielle Anwendungen

Unterschiedliche Industrien und Anwendungsbereiche haben unterschiedliche Anforderungen an die Reinheit von Oberflächen. Dockweiler bietet hier eine Vielzahl an unterschiedlichen Reinigungsverfahren an: Angefangen von der Reinigung der Innenoberflächen nach ASTM A632, S3 über Trockenreinigungsverfahren bis hin zu modernsten hochreinen Ultraschall- und Vakuumreinigungsverfahren mit anschließender Restgasanalyse. Und das auch für hochkomplexe Geometrien und kapillare Strukturen.

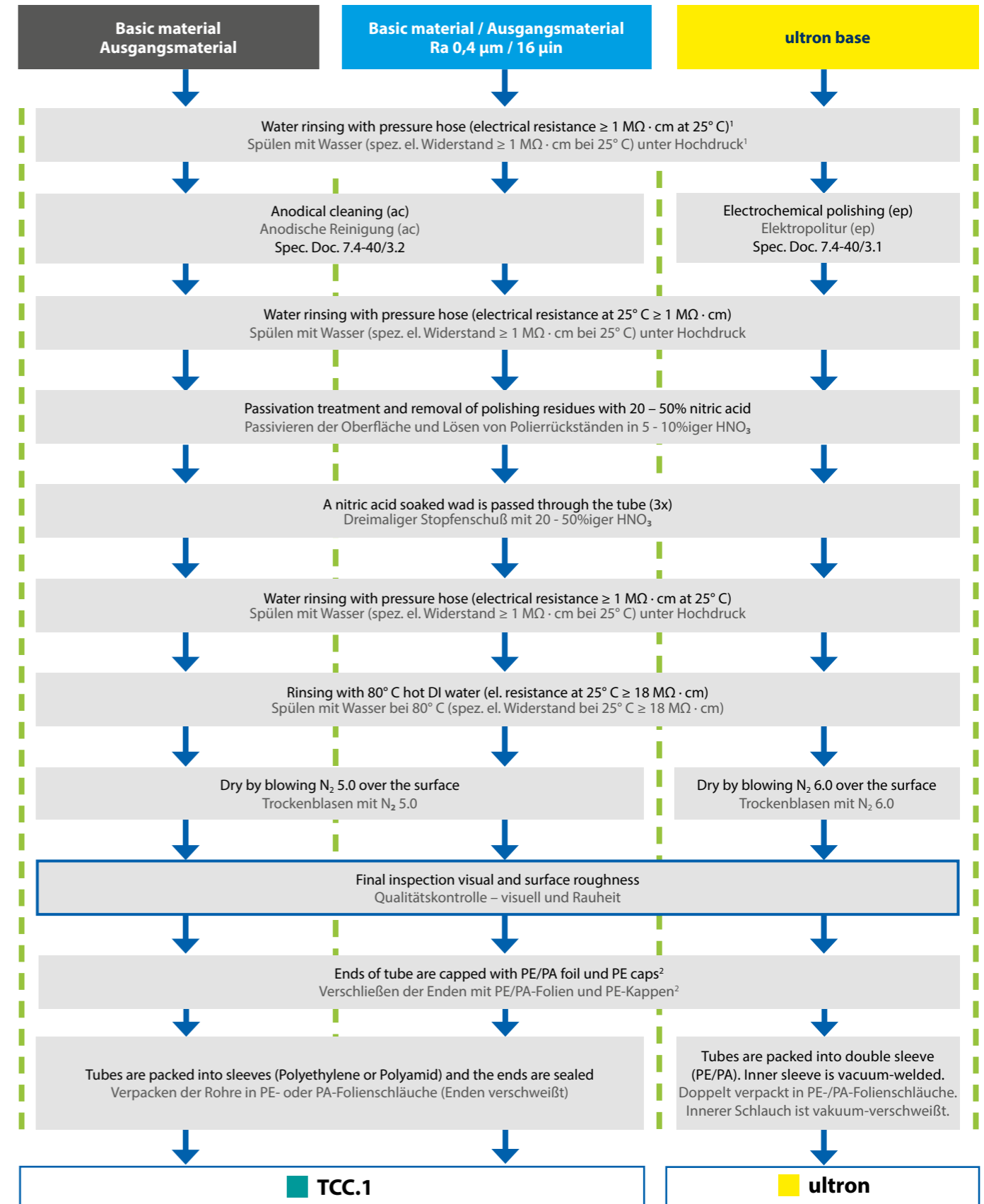

<sup>1</sup> If tubes are contaminated with dirt, dust or oil after mechanical treatment, e.g. honing, they are cleaned with an alkaline or acid detergent before any further treatment.  
<sup>2</sup> If the marking is hardly legible after the frequent cleaning steps, tubes will be marked again.

<sup>1</sup> Sollten die Rohre durch mechanische Bearbeitungsschritte, wie z.B. Honen, Verunreinigungen aufweisen, so werden diese zuvor durch ein alkalisches oder saures Reinigungsbad entfernt.  
<sup>2</sup> Ist die Beschriftung der Rohre durch die zahlreichen Waschvorgänge unleserlich, werden diese neu bestempelt.

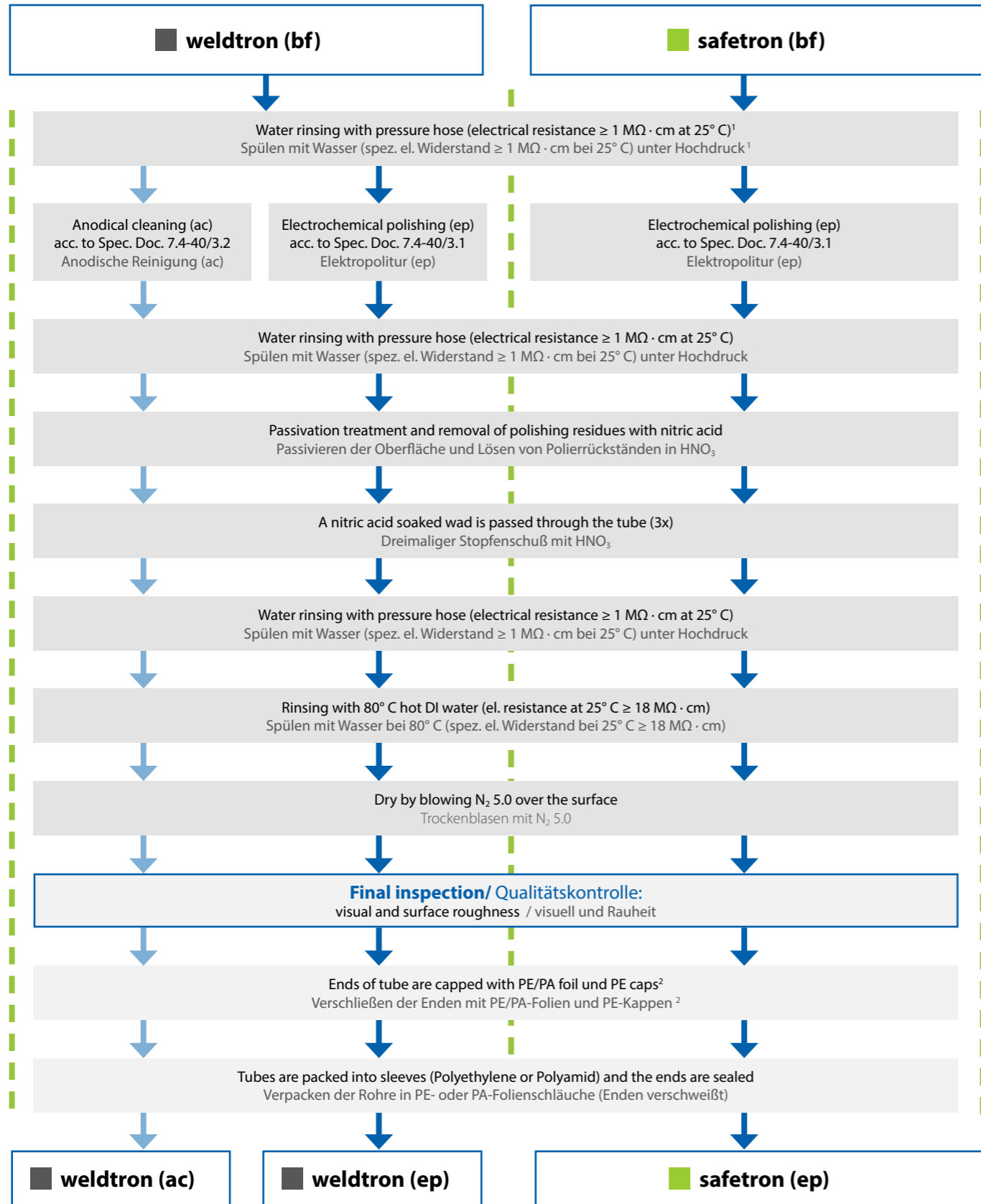

<sup>1</sup> If tubes are contaminated with dirt, dust or oil after mechanical treatment, e.g. honing, they are cleaned with an alkaline or acid detergent before any further treatment.  
<sup>2</sup> If the marking is hardly legible after the frequent cleaning steps, tubes will be marked again.

<sup>1</sup> Sollten die Rohre durch mechanische Bearbeitungsschritte (wie z. B. Honen) Verunreinigungen aufweisen, so werden diese zuvor durch ein alkalisches oder saures Reinigungsbad entfernt.  
<sup>2</sup> Ist die Beschriftung der Rohre durch die zahlreichen Waschkvorgänge unleserlich, werden diese neu bestempelt.

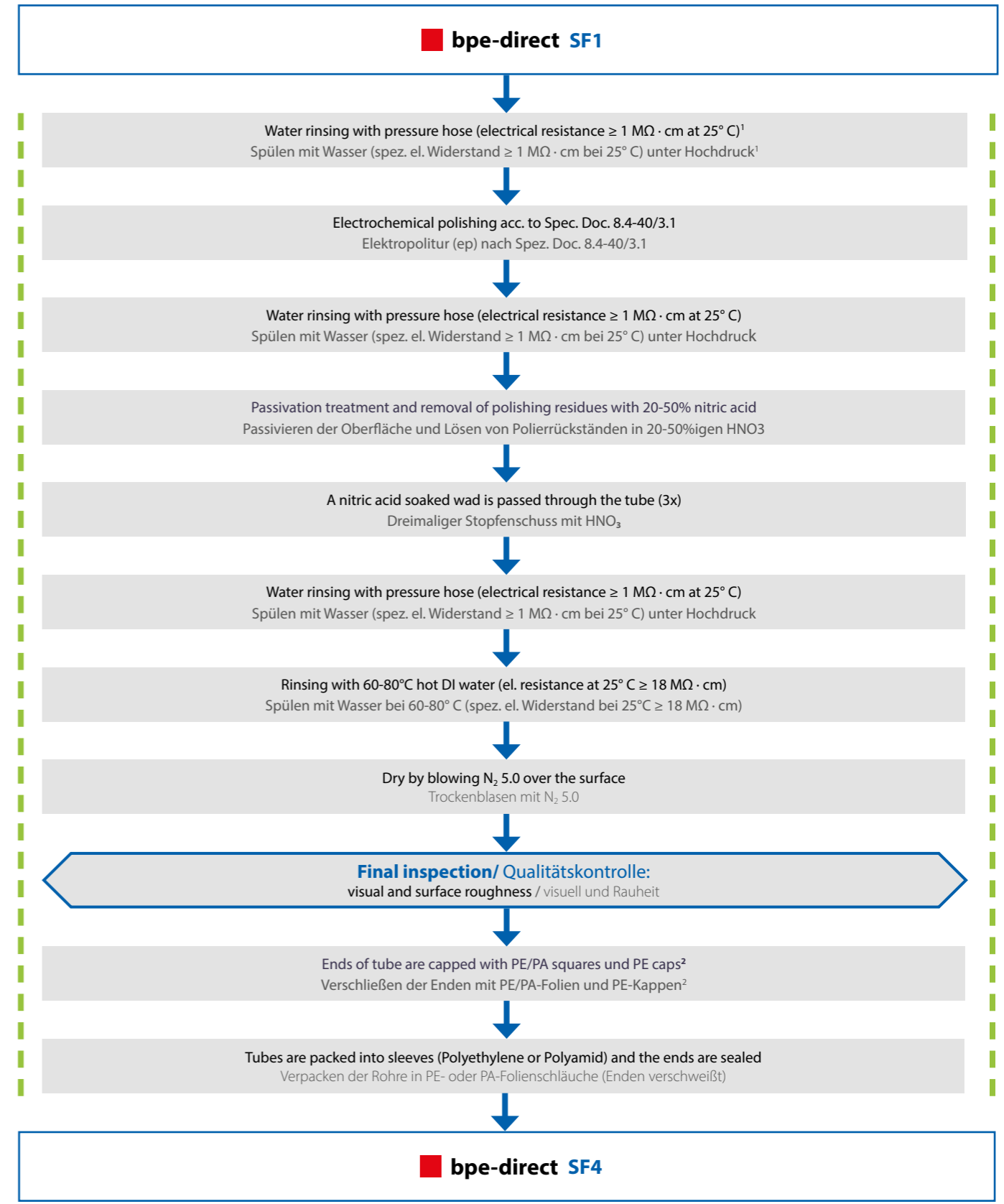

<sup>1</sup> If tubes are contaminated with dirt, dust or oil after mechanical treatment, e.g. honing, they are cleaned with an alkaline or acid detergent before any further treatment.  
<sup>2</sup> If the marking is hardly legible after the frequent cleaning steps, tubes will be marked again.

<sup>1</sup> Sollten die Rohre durch mechanische Bearbeitungsschritte, wie z. B. Honen, Verunreinigungen aufweisen, so werden diese zuvor durch ein alkalisches oder saures Reinigungsbad entfernt.  
<sup>2</sup> Ist die Beschriftung der Rohre durch die zahlreichen Waschkvorgänge unleserlich, werden diese neu bestempelt.

**Dockweiler AG**

An der Autobahn 10/20  
19306 Neustadt-Glewe  
Germany

☎ + 49 38757 58-0

✉ sales@dockweiler.com

Your local office



[www.dockweiler.com](http://www.dockweiler.com)

Find your local partner and further informations.  
Finden Sie den Ansprechpartner in Ihre Nähe  
und weitere Informationen.